

Thermal Processing

Canning and Aseptic Processing

COOKING

- Baking
- Broiling
- Roasting
- Boiling
- Stewing
- Frying
- To make food more palatable, improve taste:
 - Alteration of color, flavor, texture
 - Improved digestability
- Not a preservation technique but:
 - Destroy or reduce m.o.
 - Inactivation of enzymes
 - Destruction of toxins

Commercial Sterilization

- Operation in which product is placed in a hermetic container (canned foods), heated at a sufficiently high temperature for a sufficient length of time to destroy all microbial and enzyme activity (Note - "commercial sterility" implies less than absolute destruction of all micro-organisms and spores, but any remaining would be incapable of growth in the food under existing conditions).
- Severity of treatment can result in substantial changes to nutritive and sensory characteristics

Definitions

- Disinfection
- Sanitation
- Sterilization
- Commercial Sterilization
- Low-acid foods
- Acid foods
- Acidified foods
- pH
- A_w

Methods of sterilization

- In-package sterilised, in which product is packed into a container, and the container of product is then sterilised eg canned, eg some bottled products, retort pouches
- UHT or Aseptically processed products, in which the product and the package is sterilised separately, then the package is filled with the sterile product and sealed under sterile conditions eg “long life” milk, “tetrapack” or “combibloc” fruit juices and soups etc

Commercial sterilization

Destroys both vegetative cells and spores of pathogenic & spoilage microorganisms that would be capable of growing in the product under normal storage conditions

Types of Products:

- Retorted
- Aseptically packaged

Commercially Sterile Foods

- Primary objective:
Destroy the most heat resistance pathogenic spore-forming organisms --- ex.- *Clostridium botulinum* in products > pH 4.6
- Secondary objective:
Destroy vegetative and spore-forming microorganisms that cause spoilage.
Spoilage spore-formers are usually more heat resistant than pathogenic spore formers.

High vs. Low Acid Foods

- **Foods can be classified on the basis of pH**

> pH 4.6 are low acid foods

< pH 4.6 are acid foods

We also need to know that if the A_w of food is <0.85, it can be classified as acid at $\text{pH} > 4.6$.

Processing times and temperatures are lower for acid foods because....

- microorganisms are more easily destroyed in an acid environment
- *C. botulinum* spores cannot germinate below pH 4.6.

Length of heating process

- Heat resistance of m.o.
- Heating conditions
- pH and composition of food
- Size of the container
- Physical state of food material

Information needed for heat process

- Heat resistance of m.o.
- Rate of heat penetration
- Sensory/quality of product

Heat resistance of m.o.

- Refer to Ch. 1, Sect. 1.4.5
- Table 12.1
- Characteristics of *Clostridium botulinum*
- Which organism is used to determine heat penetration in low-acid foods?
- What are the parameters used for this?
- Which organism is used to determine heat resistance in acid foods?
- What are the parameters for this?

Classification of foods by pH

- Low-acid ($\text{pH} > 4.6$)
- Acid ($\text{pH} < 4.6$)
- High acid ($2.5 < \text{pH} < 3.7$)
- High acid, high solids (jams)

Heat resistance of m.o. and spores

- Low-acid
 - *Clostridium botulinum*
- Acid
 - *Bacillus thermoacidurans*

Rate of heat penetration

- Type of product
- Agitation of container
- Retort temperature
- Size of container
- Shape of container
- Type of container

F

- The time, in minutes, at a specified temperature required to destroy a specific number of viable cells having a specific z-value.

F₀

Sterilization value or sum of lethality rate that will insure commercial sterilization or equivalent minutes at 250 F to get 12D

$$F_0 = \text{Sum } (1/t)$$

Lethality curve for canned *L. monocytogenes* in crabmeat (Rippen, 2002)

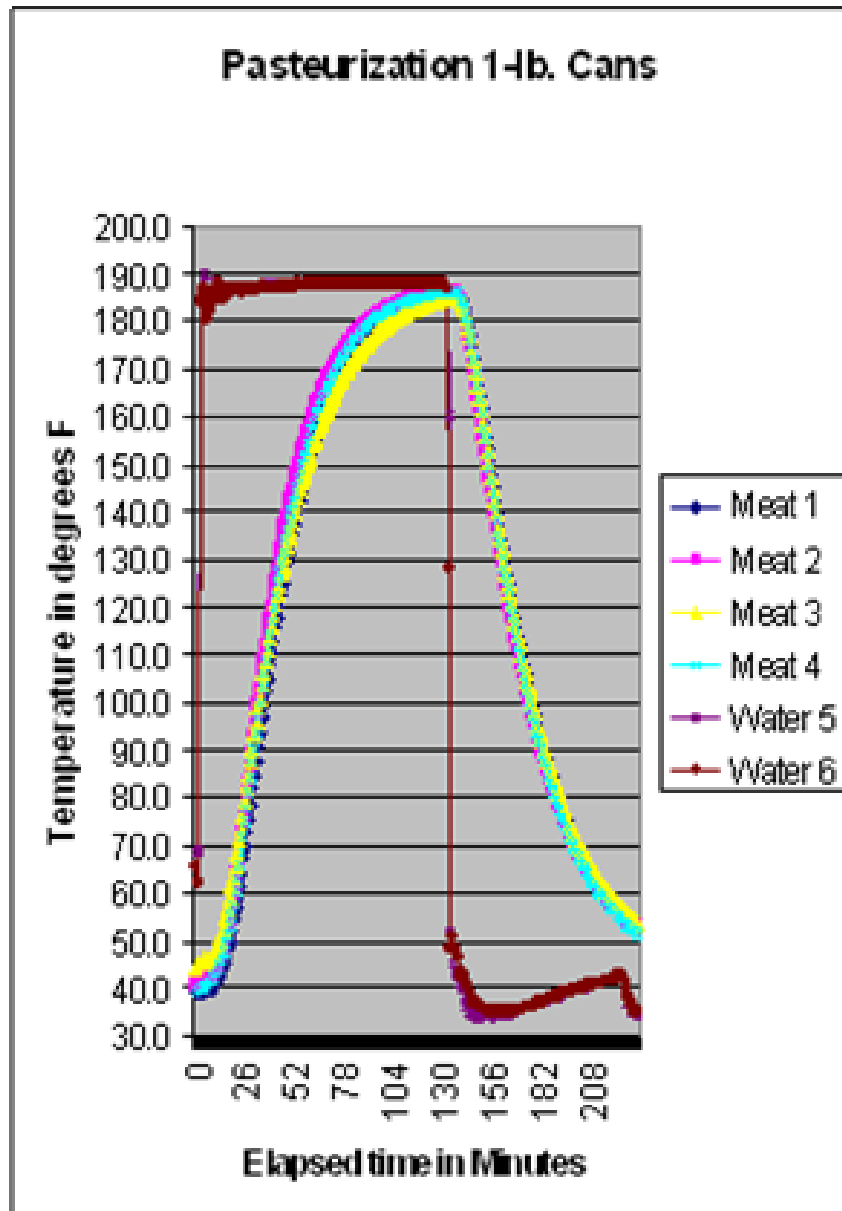

$$F = 10^{\left(\frac{T-185}{16}\right)} \times \text{time interval}$$

5-D Process

5 D process = time/temperature process that will reduce the *Bacillus stearothermophilus* population by 5 log cycles.

- Used for acid (< pH 4.6) canned foods.

12-D Process

12 D process = time/temperature process that will reduce the *Clostridium botulinum* spore population by 12 log cycles.

- Required for low acid ($> \text{pH } 4.6$) canned foods.

C. botulinum spores 100 spores/can

→

12 D process

C. botulinum spores 10^{-10} spores/can
(1 in 10^{10} chance)

Table 2 D-values and z-values for some bacterial spores

Spore	Moist heat		Dry heat	
	<i>D</i> (min) at 121°C	<i>z</i> (°C)	<i>D</i> (min) at 160°C	<i>z</i> (°C)
<i>B.subtilis</i>	<1	5.5–9.5	1–5	20
<i>B.cereus</i>	<1			20
<i>Cl.sporogenes</i>	<1	10	2	20
<i>Cl.botulinum</i> type A	<1	10		
<i>B.stearothermophilus</i>	4-5	8–10	<1	15–25

Table 3 Sites of damage in non-sporulating bacteria exposed to moist heat

Site	Damage ^a
Cell wall (Gram-positive)	Probably not significant (PTG confers some protection?)
Outer membrane (Gram-negatives)	Affected to some extent by high temperatures
Cytoplasmic (inner) membrane	Severe damage (heat stability varies with M.Pt of cell lipids); cells become leaky; leakage precedes death
Ribosomes and ribosomal RNA	Degradation; precedes loss of viability
DNA	SSB, partly a consequence of nuclease activity; repair of SSB in radiation-resistant but not -sensitive bacteria
Proteins	Denaturation, especially at high temperatures (possible coagulation)
Enzymes	Inactivation, especially at high temperatures

^aPTG, peptidoglycan; M.Pt., melting point; SSB, single strand breaks

Table 6 Sites of damage in bacterial spores exposed to moist heat

Site	Damage
Spore coats	Not considered significant
Cortex	Not considered significant ^a
Membranes	Significant damage; DPA leakage
Protoplast	Protein denaturation, DNA strand breakage

^aCortex is major factor controlling heat resistance of spores to moist heat.

Table 1. Number of CFU/g of chestnut puree canned before and after the thermal treatment chosen as the best (110°C/50min).

	*CFU/g	*CFU/g
Mesophilic aerobes	1850 ± 130	98 ± 12
Mesophilic anaerobes	2500± 200	123 ± 17
Thermophilic aerobes	1330± 150	59 ± 4
Thermophilic anaerobes	1900 ± 50	76 ± 3
Psicotrophilic	28,000 ± 20,000	10 ± 2
<i>Salmonella</i>	20 ± 1	0
Sulphite reducing Clostridia	100 ±3	0
<i>Staphylococcus aureus</i>	200 ± 6	0
<i>Enterococcus</i>	100 ± 4	0
<i>E.coli</i>		
Yeast and molds	141000 ± 1530	0

Retorted Foods

- Product processed in the package – can, flexible pouch or glass
- Retorts (Pressure processors)
 - Still
 - Rotary
 - Hydrostatic cooker (pressure provided by a 40 – 50 feet of head pressure)
- Processing time depends on heating the most slowly heating part of the product.

Thermal Processing- Canning

- The usual heat transfer fluids are:
 - saturated steam
 - water
 - steam - air mixture
- Retorts may either be:
 - vertical
 - horizontal
 - still
 - agitating
 - batch
 - continuous

OPERATIONS IN CANNING

- Inspection of incoming raw materials
- Food preparation (thawing, cleaning, washing, sorting, grading, peeling, trimming, slicing or dicing for vegetables and fruits. Meats and fish may be tempered, boned, trimmed, diced, minced or sliced etc.
- Blanching
- Filling the container
- Exhausting
- Sealing the container
- Heat processing
- Cooling
- Incubation and quality control checks
- Labeling, palletizing, warehousing and dispatch

Blanching methods

- **Steam blanching** - less loss of water soluble nutrients
leaching - oxidation of product becomes a problem
- **Water blanching** - fast process due to a better rate of heat transfer
 - severe on nutrients
 - effective washing process
 - blanch water can be used to transport the raw materials to the next stage of the process
- **Microwaves** - very expensive and complex equipment is required - low leaching losses
- **Hot Gas** - expensive - hot gas from a furnace is blown down through the product along with steam which reduces dehydration and increases the heat transfer rate

Filling

- At this stage the food is placed into the container. **Underfilling** gives a large headspace. Large headspaces result in the following:
 - **Low vacuum if heat exhaust is used.**
 - **Mushiness of the contents due to excessive movement inside the can.**
 - **Contravening the Pure Food Act Regulations due to underfilling.**
- **Overfilling** produces excessively small headspaces, resulting in the following:
 - Low vacuum if steam flow closure is relied on for vacuum.
 - Swelling of can due to hydrogen production.
 - Under processing if the process depends on agitation to mix the contents during processing.
 - Springiness or distortion of can.
 - Increased chance that food may be trapped between the can lid and body with the production of a faulty seam.
- The cans are periodically weighed on line, headspaces, drained and net weights are determined on the finished products in order to check the adequacy of the filling process.

Automatic filler

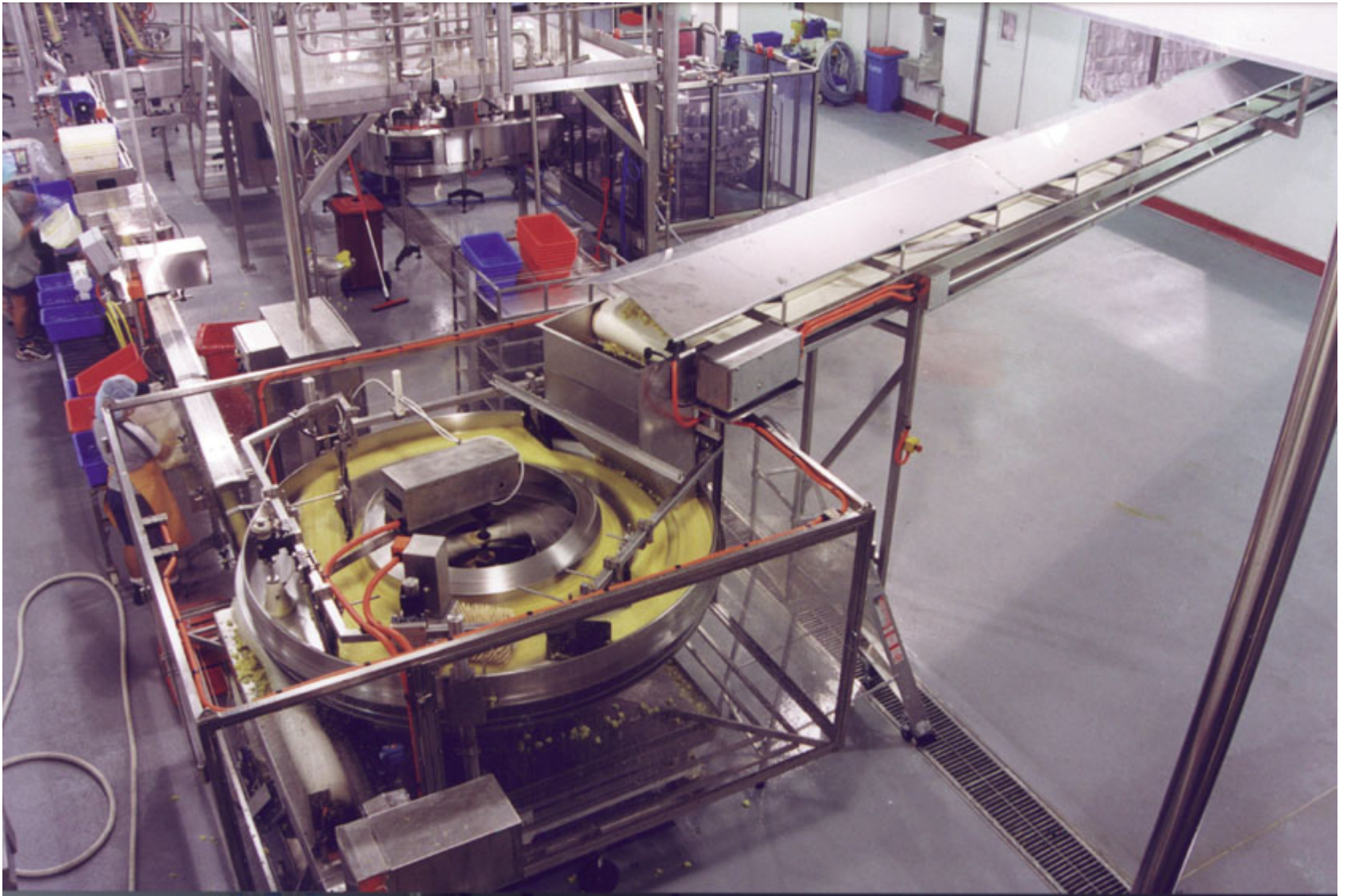







Exhausting

- Exhausting aims to remove air from the package before closure. Correct exhausting will:
 - **Remove all gases from the headspace which will minimise strains on seams during retorting.**
 - **Remove oxygen, otherwise either corrosion, oxidation and discolouration will result.**
 - **Give a vacuum on cooling to give space for the gases which are formed on storage.**
- There are three exhausting methods available:
- **HEAT EXHAUST**

Contents are heated before sealing. This is ideal for products containing lots of trapped air. Final temperature depends on closing temperature and headspace.
- **STEAM INJECTION** also referred to as **STEAM FLOW CLOSURE**

This flushes the headspace out with a jet of steam just before closing. This method is more effective where products are packed in hot brines and syrups and where a large headspace exists.
- **MECHANICAL EXHAUST**

Uses a vacuum pump to remove air from the package. Food is filled at low temperatures. This method is useful for foods which trap a great deal of air.

A vacuum gauge may be used on a cooled can to determine the vacuum of a can. The minimum acceptable pressure is about -23kPa. Desirable vacuum will vary for different products

Retort Operation

- Containers are loaded into baskets.
- The retort lid is sealed.

-**Venting** stage - Air trapped inside the retort is removed prior processing.

If air is present at a given pressure the temperature inside the retort will be lower than that attained by steam alone.

A mixture of air and steam may stratify leading to cool spots where there is air. This mixture is a less efficient heat transfer medium than steam alone. Air in the retort cuts down the heat penetration of steam by insulating the cans and can accelerate external corrosion.

- **When venting is completed** the venting valve closes and pressure begins to build up in the retort. When process temperature is reached the thermometer and pressure gauge readings must agree.

High acid foods (pH less than 4.5) are usually processed at low pressures of around 34kpa.

Low acid foods (pH greater than 4.5) are processed at 73 or 103kpa.

RETORT OPERATION

- The time from when the steam is turned on to when the process temperature is reached is the **come-up time**. Once this has finished the process begins.
- **Process time** is from the end of the come-up time to the commencement of cooling.
- During **cooling** the steam is turned off and water is added to the retort immediately to prevent overcooking.

There are **two methods of cooling**; for small cans at temperatures less than 116°C atmospheric cooling may be used.

For cans with a diameter greater than 6cm or processed at temperatures greater, than 116°C pressure cooling is used.

In **pressure cooling** the pressure around the containers is maintained by compressed air during the addition of water. The water addition causes the steam to condense and the pressure outside the package drops suddenly. As the internal pressure inside the container does not drop until the contents cool, seam distortion may occur if the external pressure is not kept high.

- At this stage can seams are very fragile and **cans must be handled** very carefully. All **water used for cooling** heat processed foods must be chlorinated to disinfect it in case water is sucked into the can during cooling.

Types of retorts

Still Retorts

- Pressure vessel
- Batch-type
- Nonagitating
- Vertical or horizontal
- With or without crates (crateless)

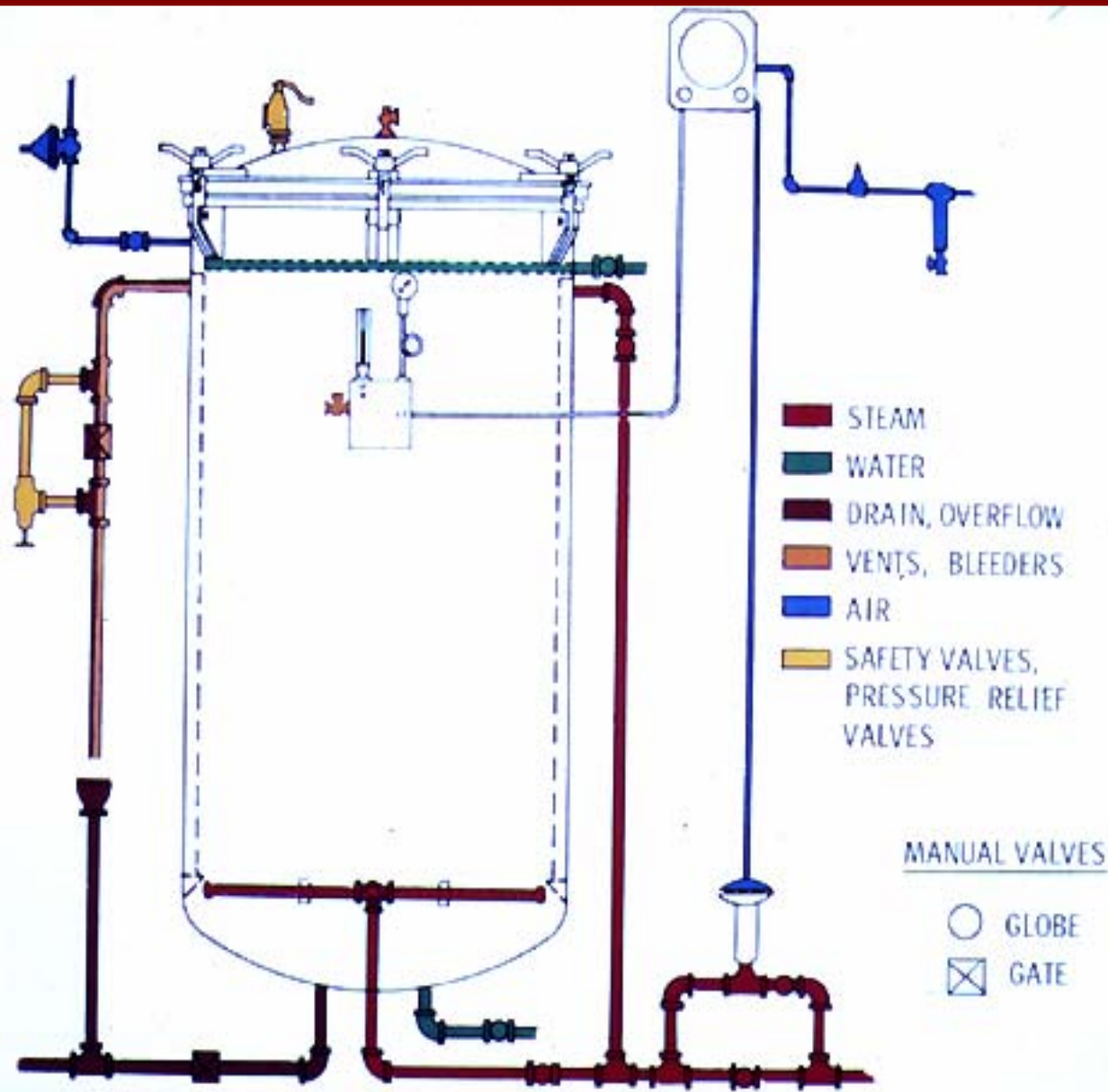

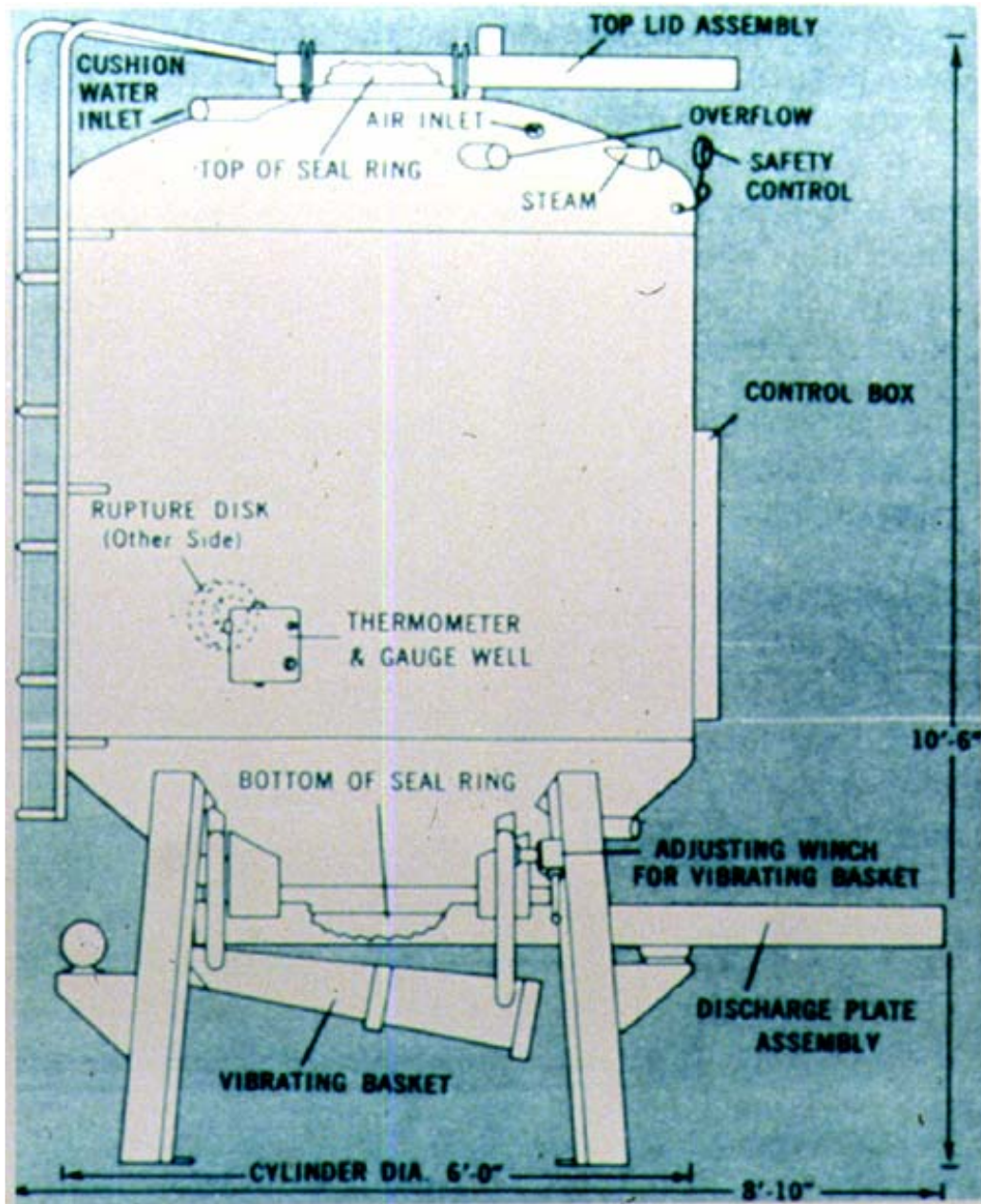

TYPICAL PROCESSING SEQUENCE

▶ WATER FLOW

▶ VENT

▶ STEAM



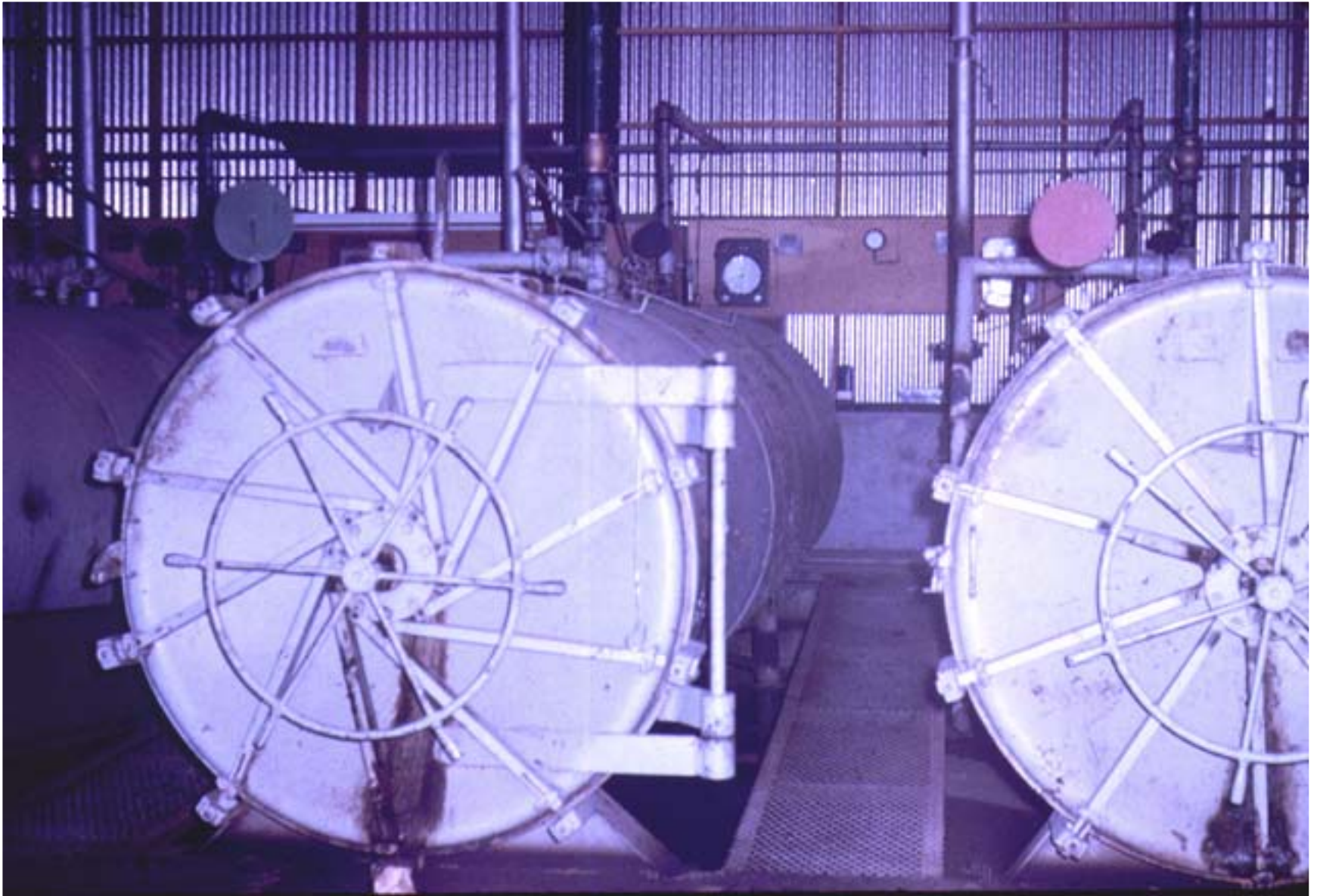

Loading a vertical retort



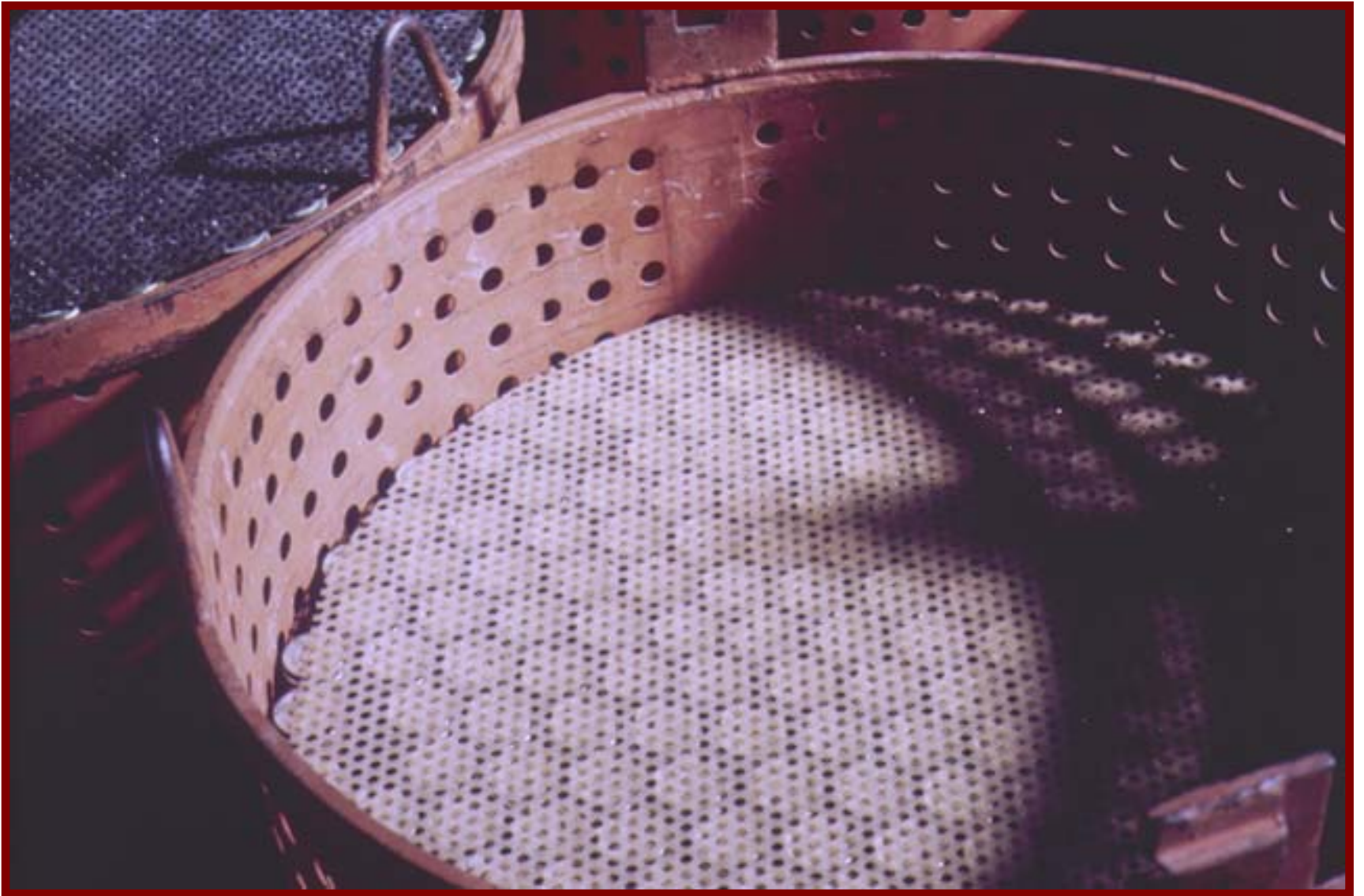

Crate

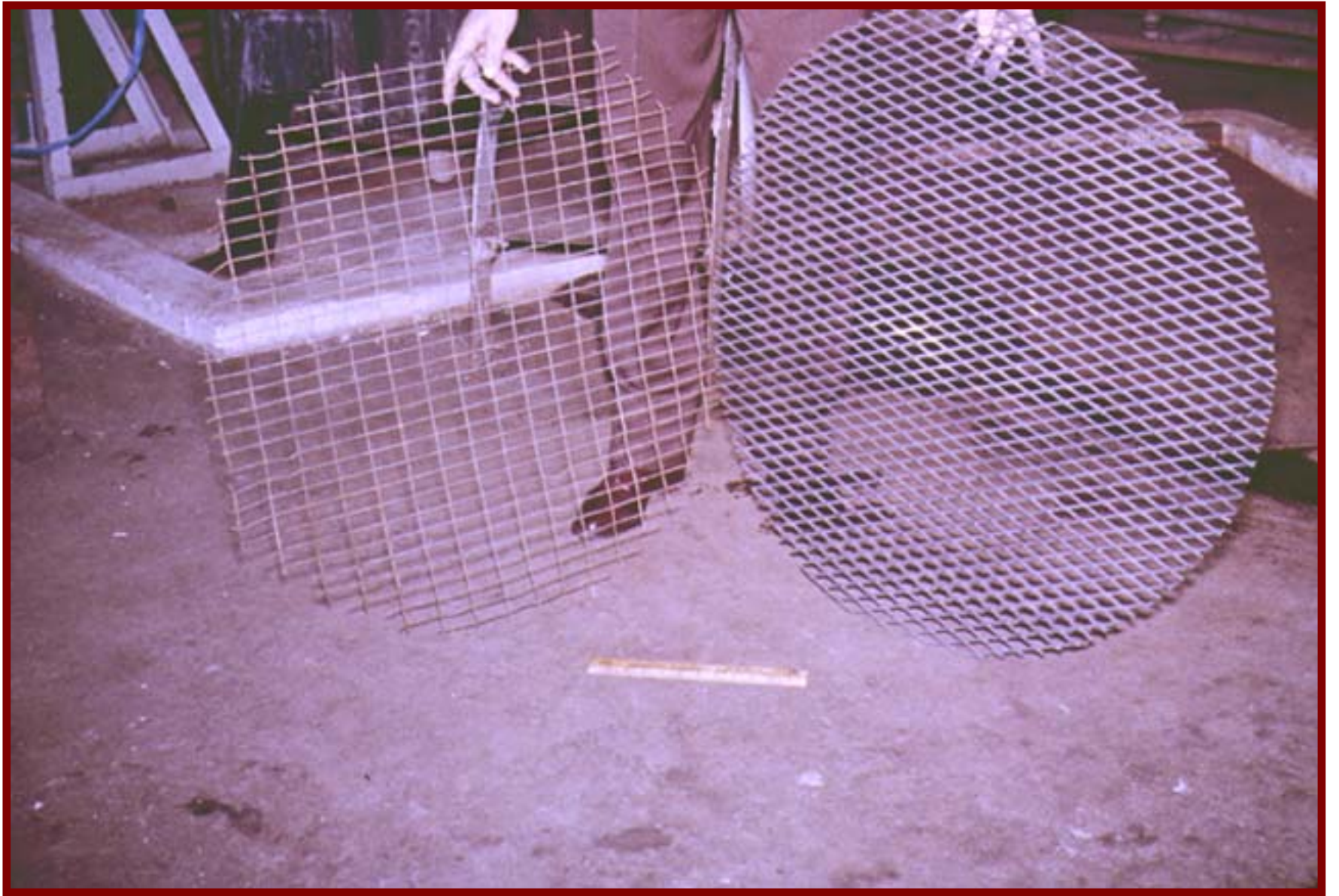



Crateless

Still Retort with Overpressure

Overpressure

- **Pressure in excess of normal pressure at a given temperature**
- **May now have air introduced to retort during processing as well as cooling**

Purpose

- **Maintain container integrity**
- **Internal pressure developed during processing is greater than pure steam pressure**

Overpressure Applications

- Plastic containers
- Flexible pouches
- Metal trays
- Glass jars

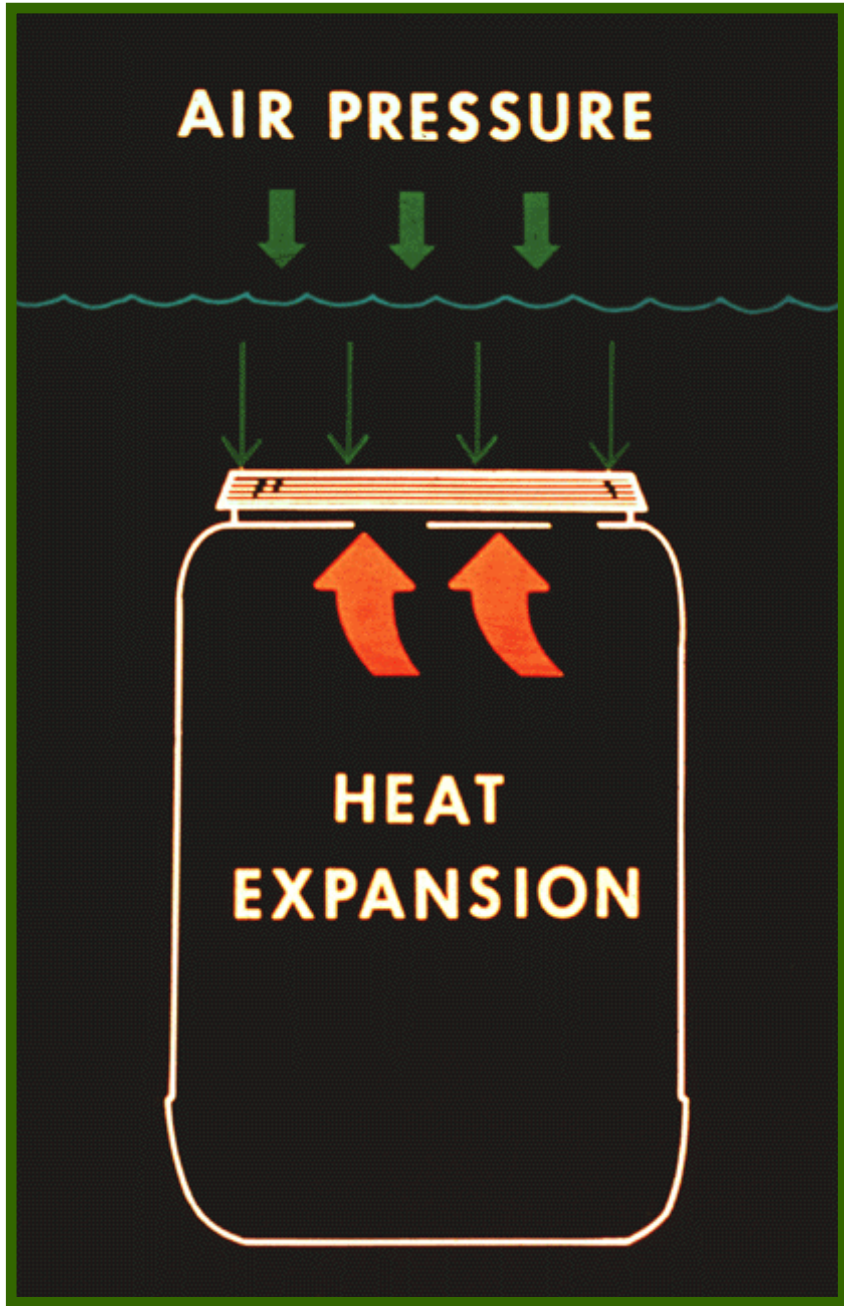

Continuous Retorts

- Still and agitating retorts may be batch or continuous. Continuous retorts have four sections:
 - can warmer
 - pressure section
 - pressure cooler
 - atmospheric cooler
- These retorts have self sealing valves which maintain pressure and tolerate temperatures up to 143°C.

AGITATING RETORTS

- **Some retorts agitate the cans during processing in order to increase the rate of heat penetration into the cans. Agitation may either be axial or end over end. Agitation is useful for products which are too viscous to heat or cool by natural convection. By using agitation, the process time may be reduced by up to 80%. Mixing is largely due to the movement of the headspace during agitation and to be effective there must be a sufficiently large headspace inside the can. A small headspace may lead to under processing.**

Agitating Retorts – Discontinuous Container Handling

- Batch container handling
- Continuous product agitation
- Variety of retort types
- End-over-end or side-over-side

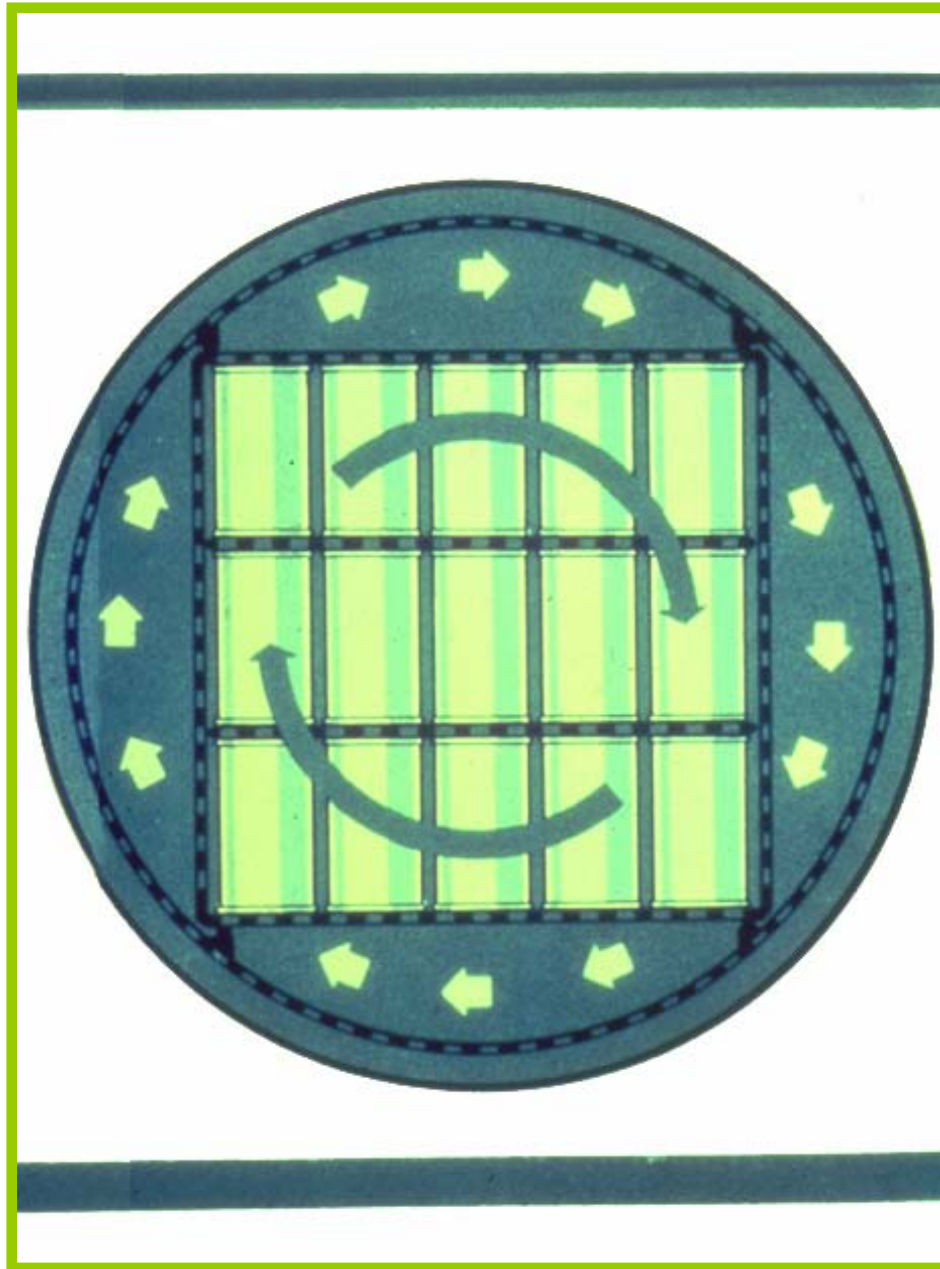





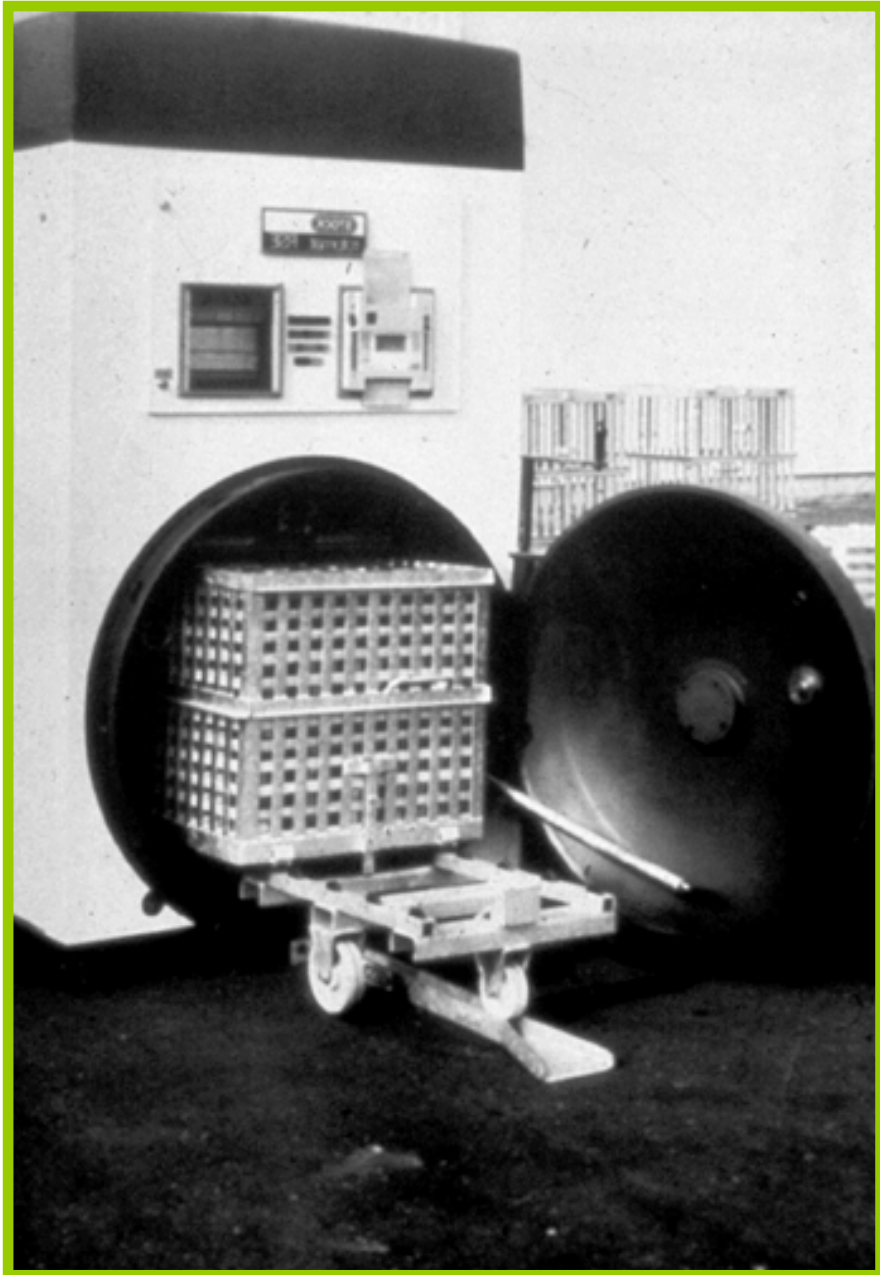

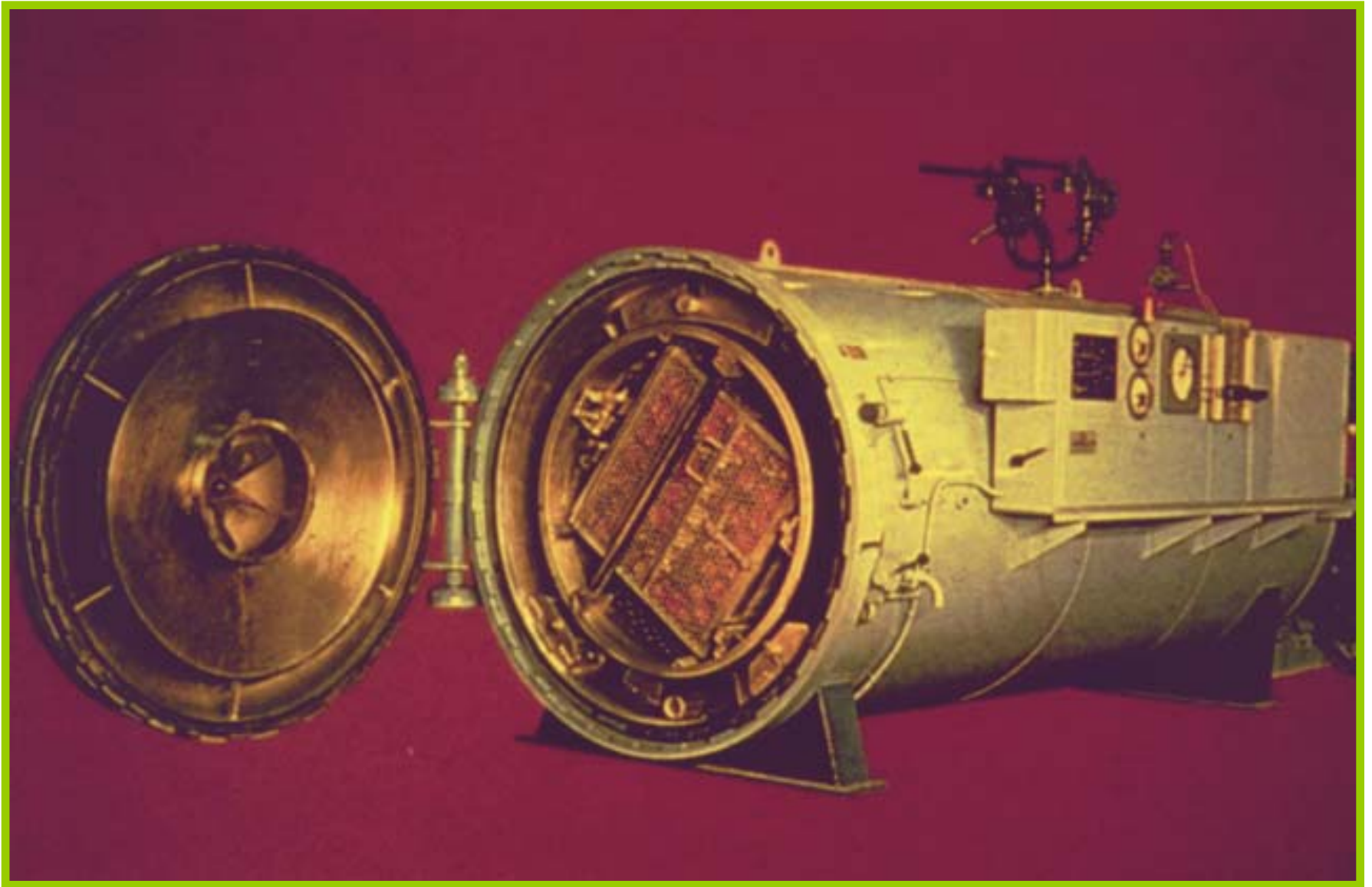

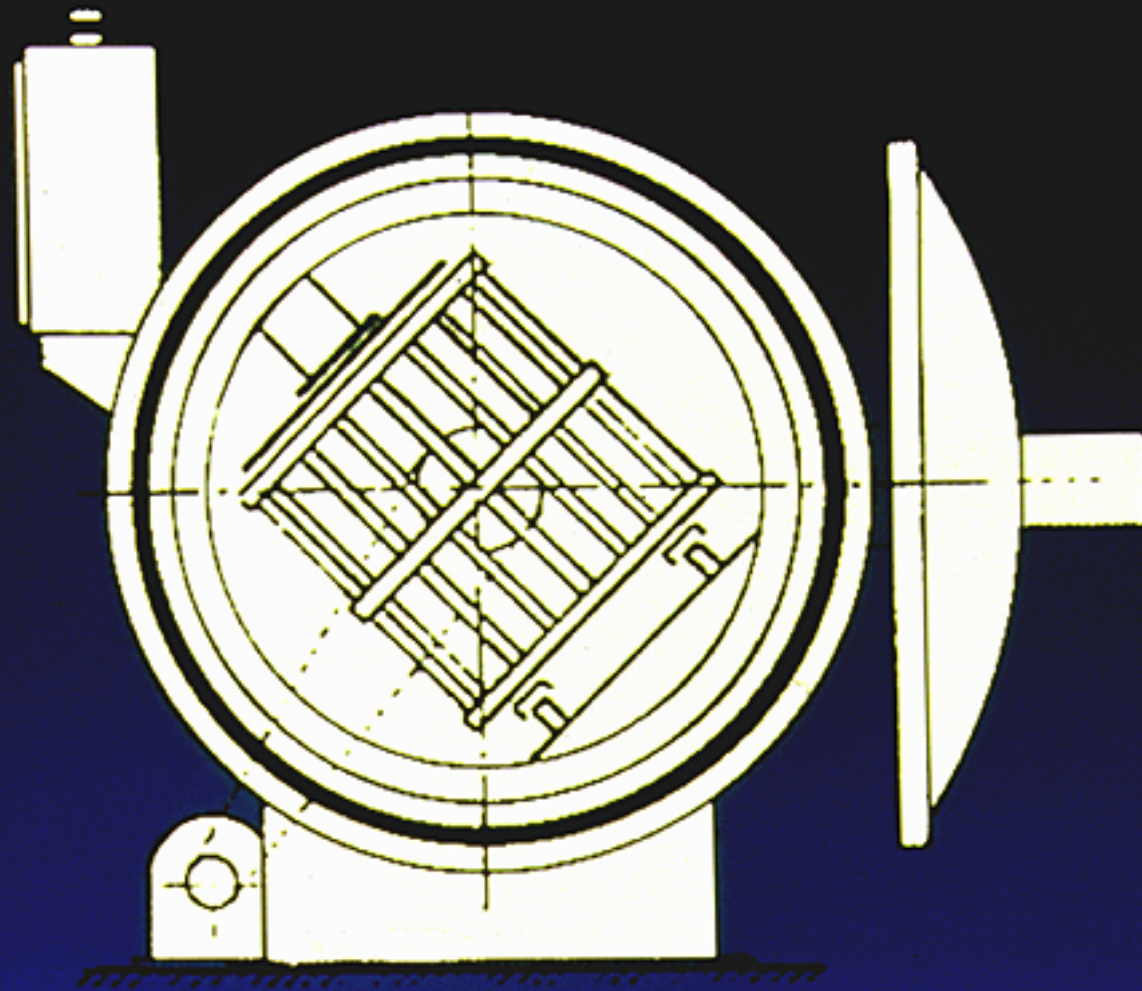

ROTARY TYPE, ϕ 1700

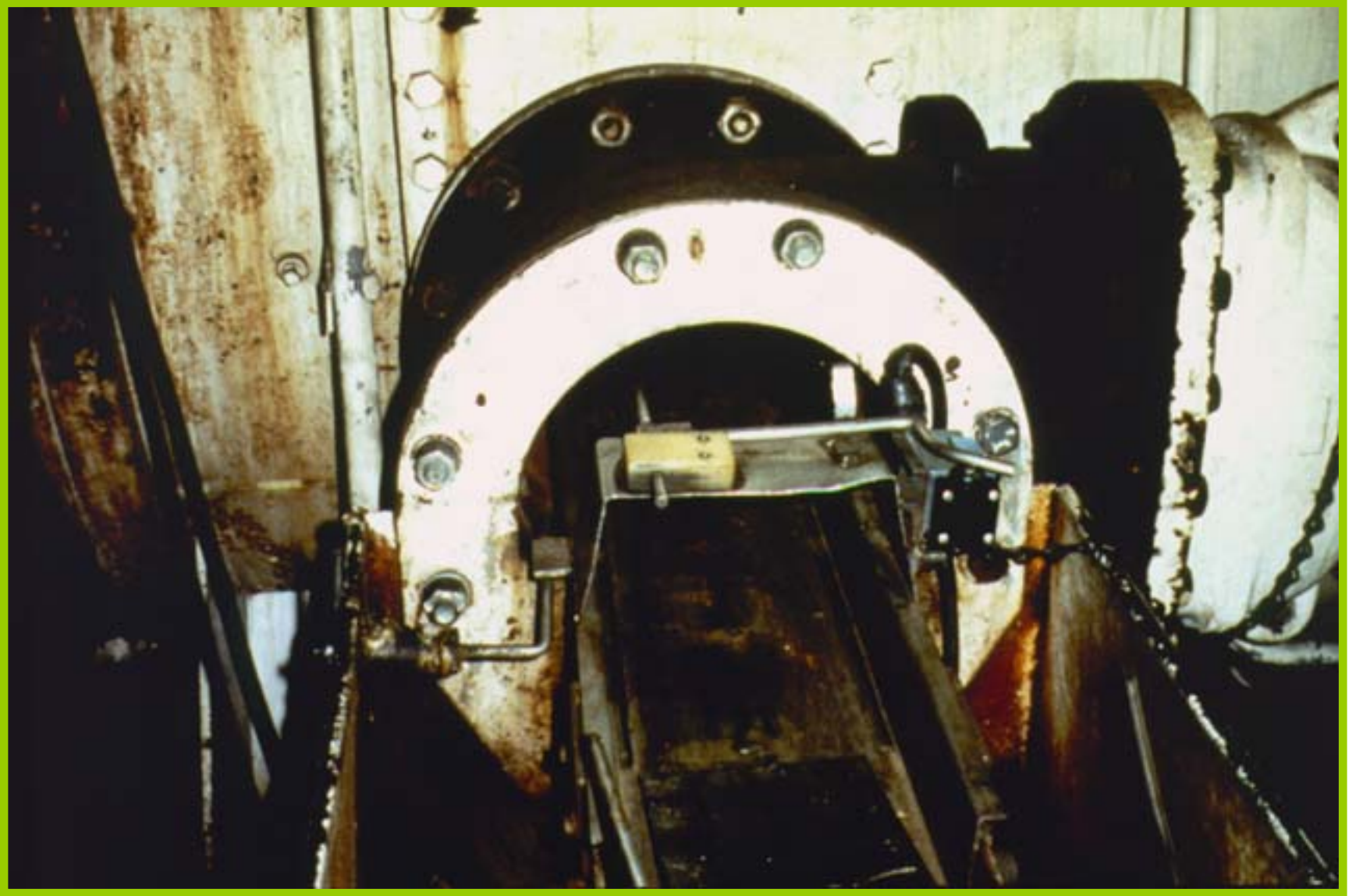

Description of Retort

End-over-end Rotation

- Containers held in place
- Rotating framework holds baskets
- Variable rotation speed
- Wide range of containers
- Custom racking system
- Various processing methods

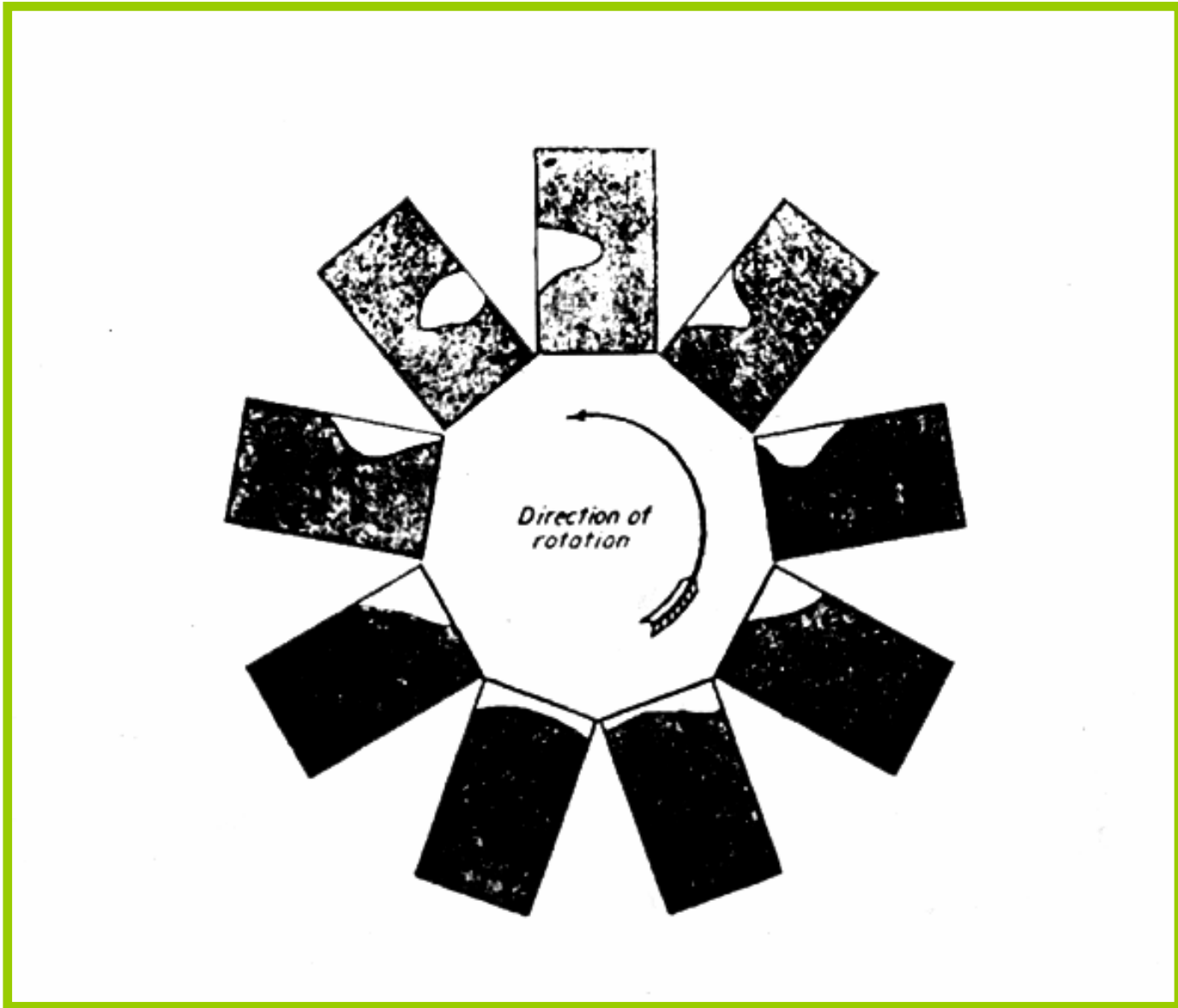

Side-Over-Side Agitation

- Steam processing medium
- Containers held in real by a spiral T
- Container size limits

OBITORT AGITATION

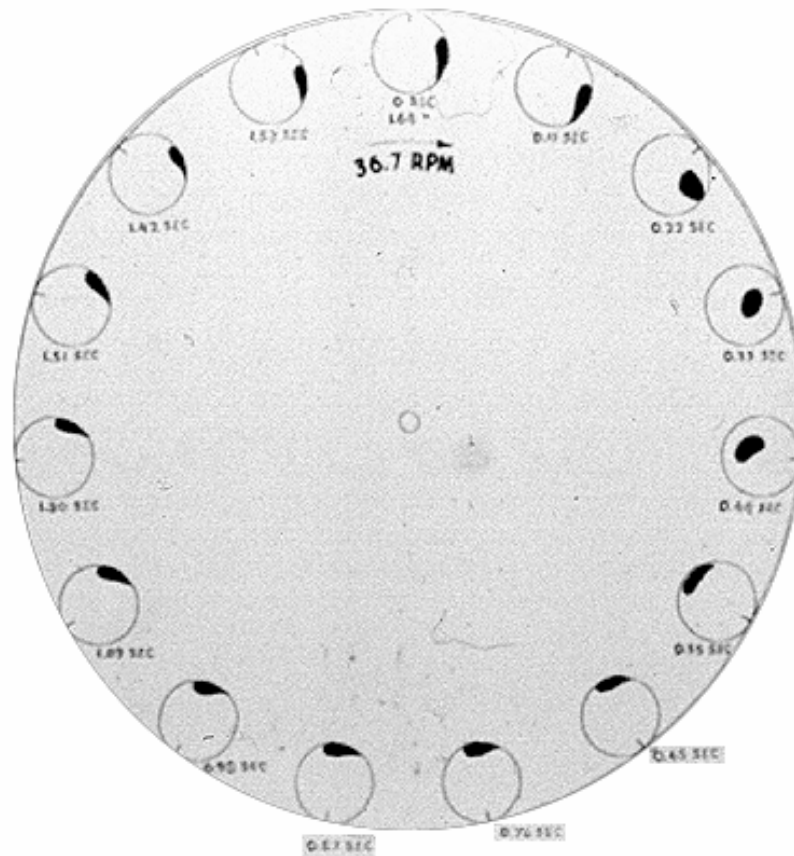

Racks for semi rigid containers



Agitating Retorts-Continuous Container Handling

- Batch container handling
- Continuous product agitation
- Variety of retort types
- End-over-end or side-over-side

Introduction

- **Continuous container handling**
- **Intermittent product agitation**
- **At least two shells**
- **Configuration will vary**

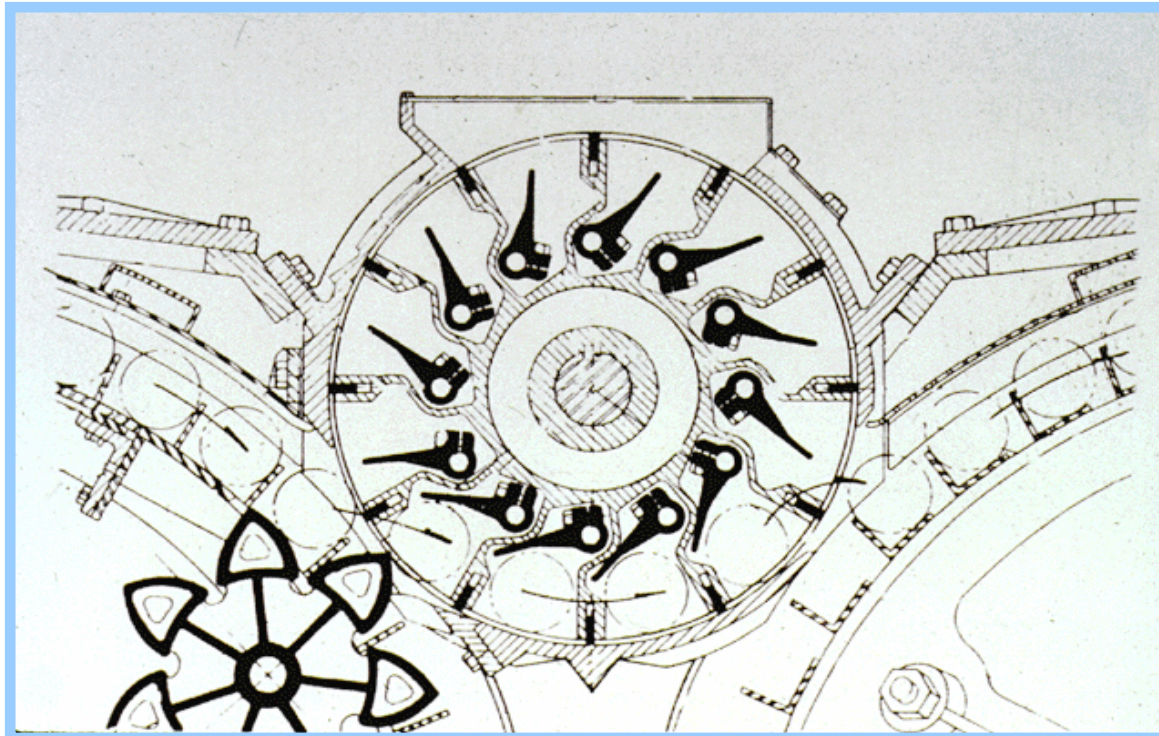

Two Shell Line Arrangement

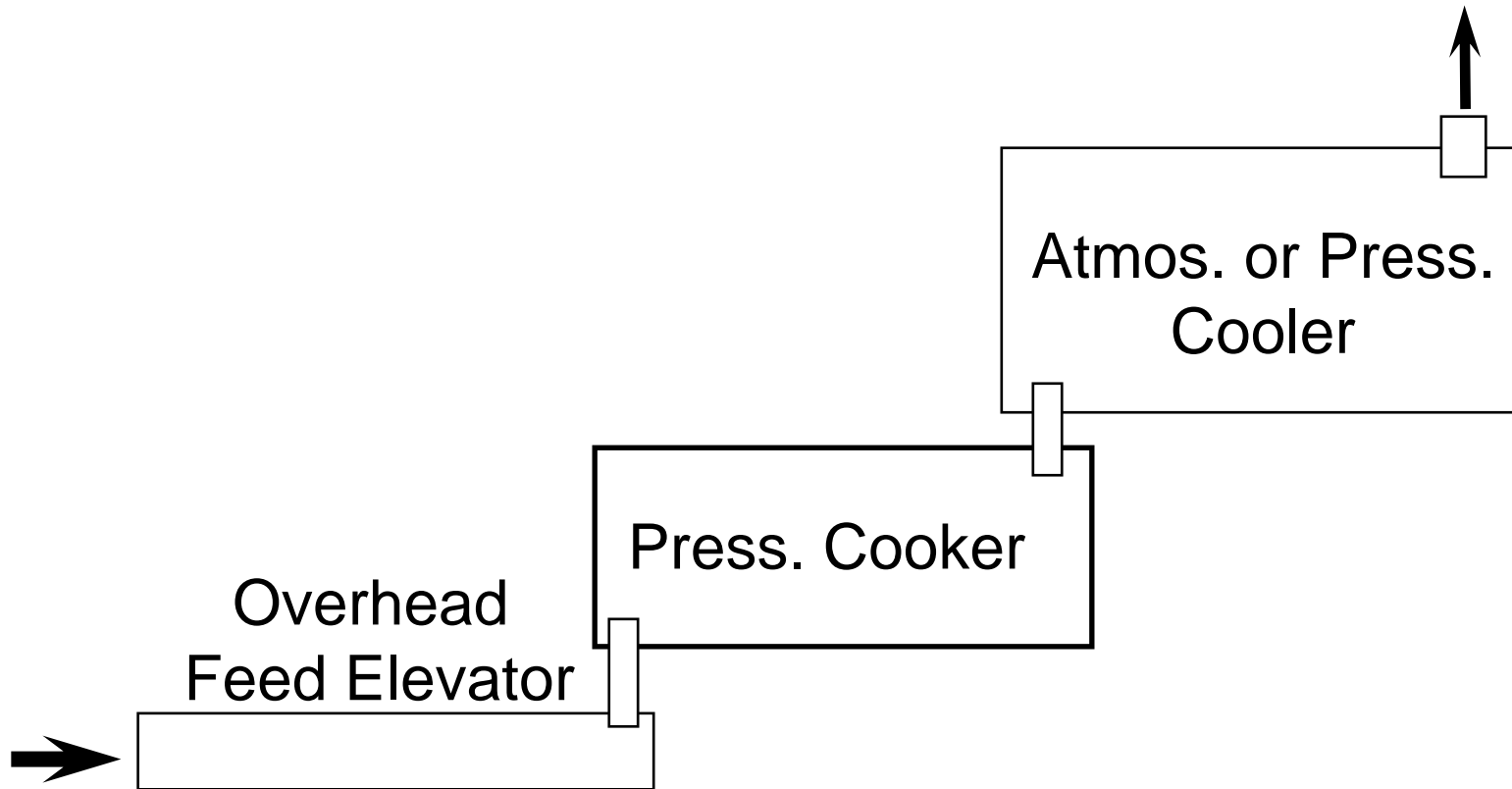

Three Shell Line Arrangement

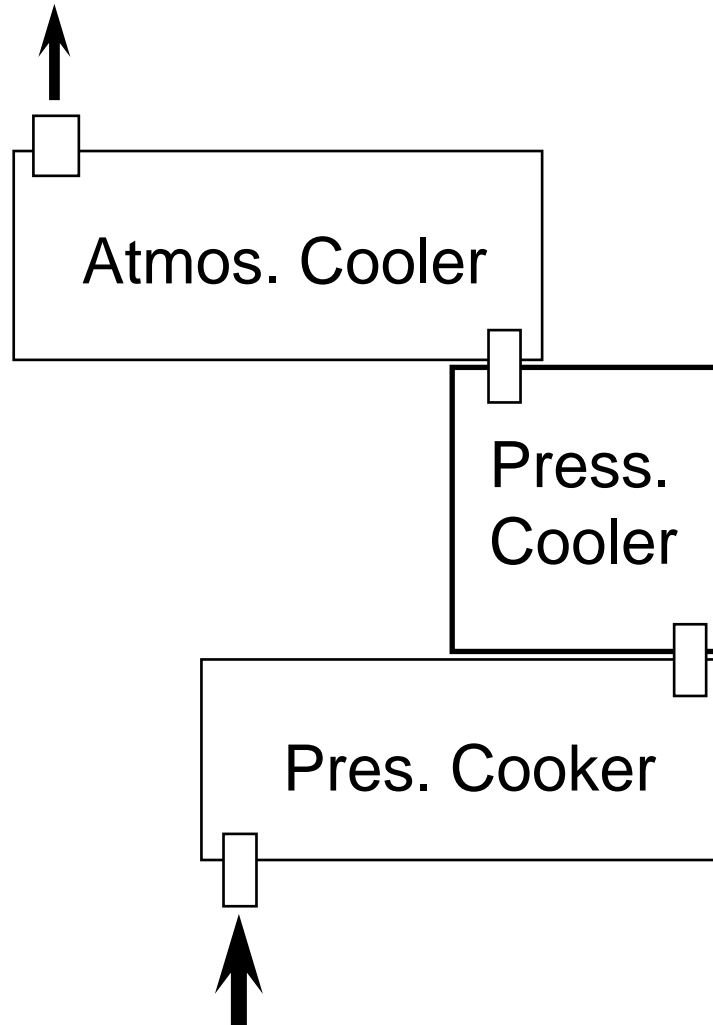

STERILMATIC
SPIRALES - SPIRALS

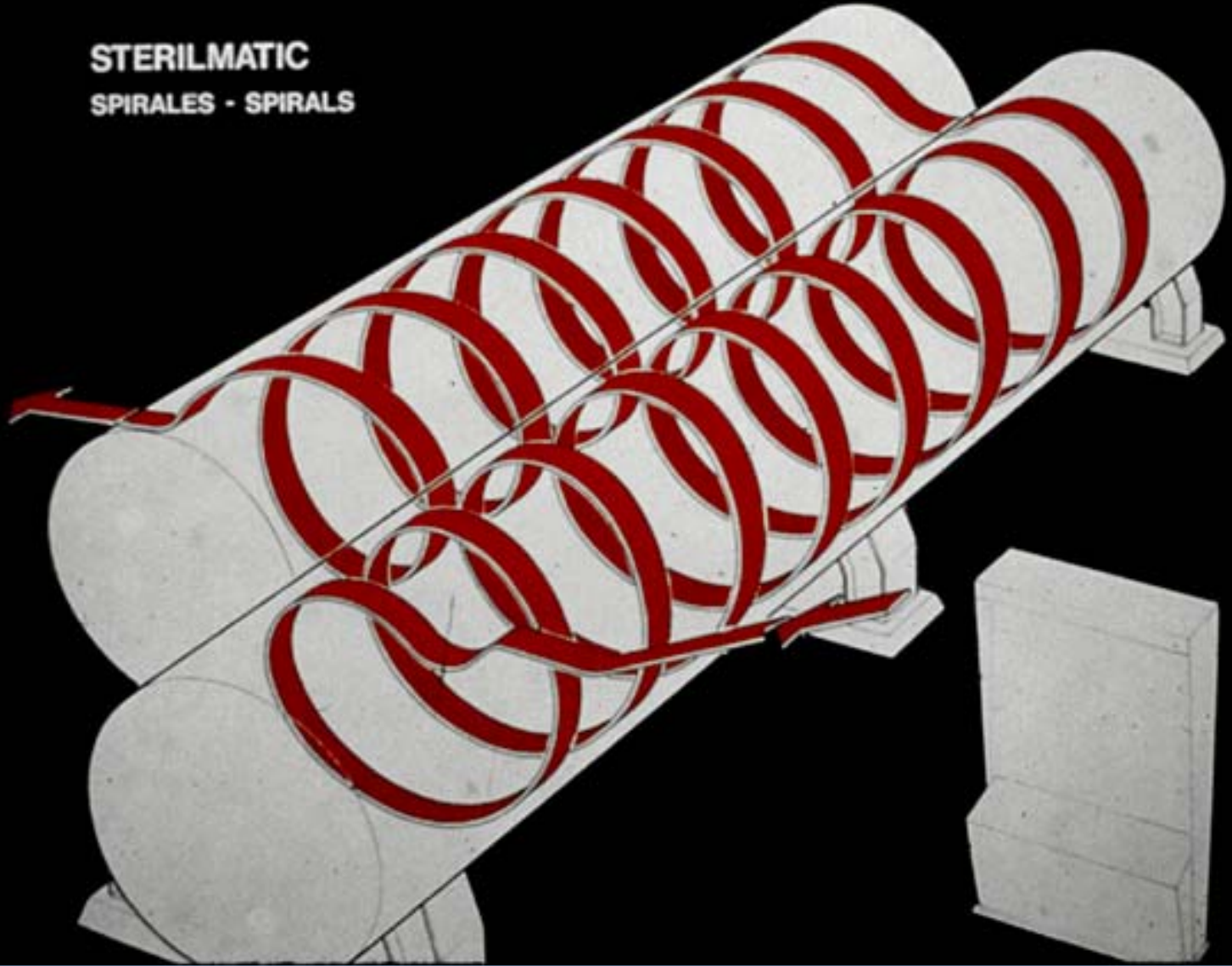

STERILMATIC
(MOD. 741)

DISCHARGE
SORTIE

INFEED
ENTREE

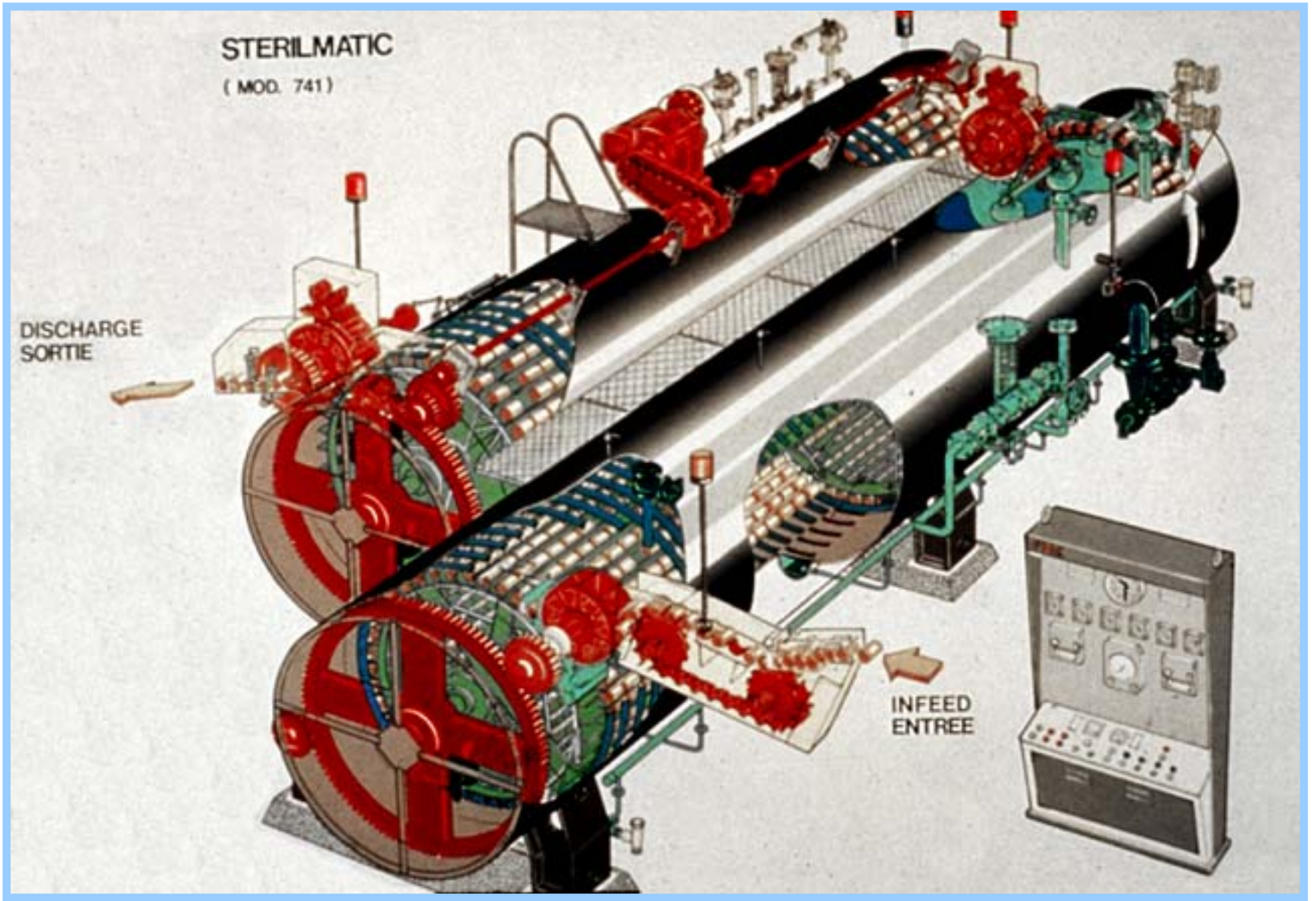

STERILMATIC - PRINCIPLE

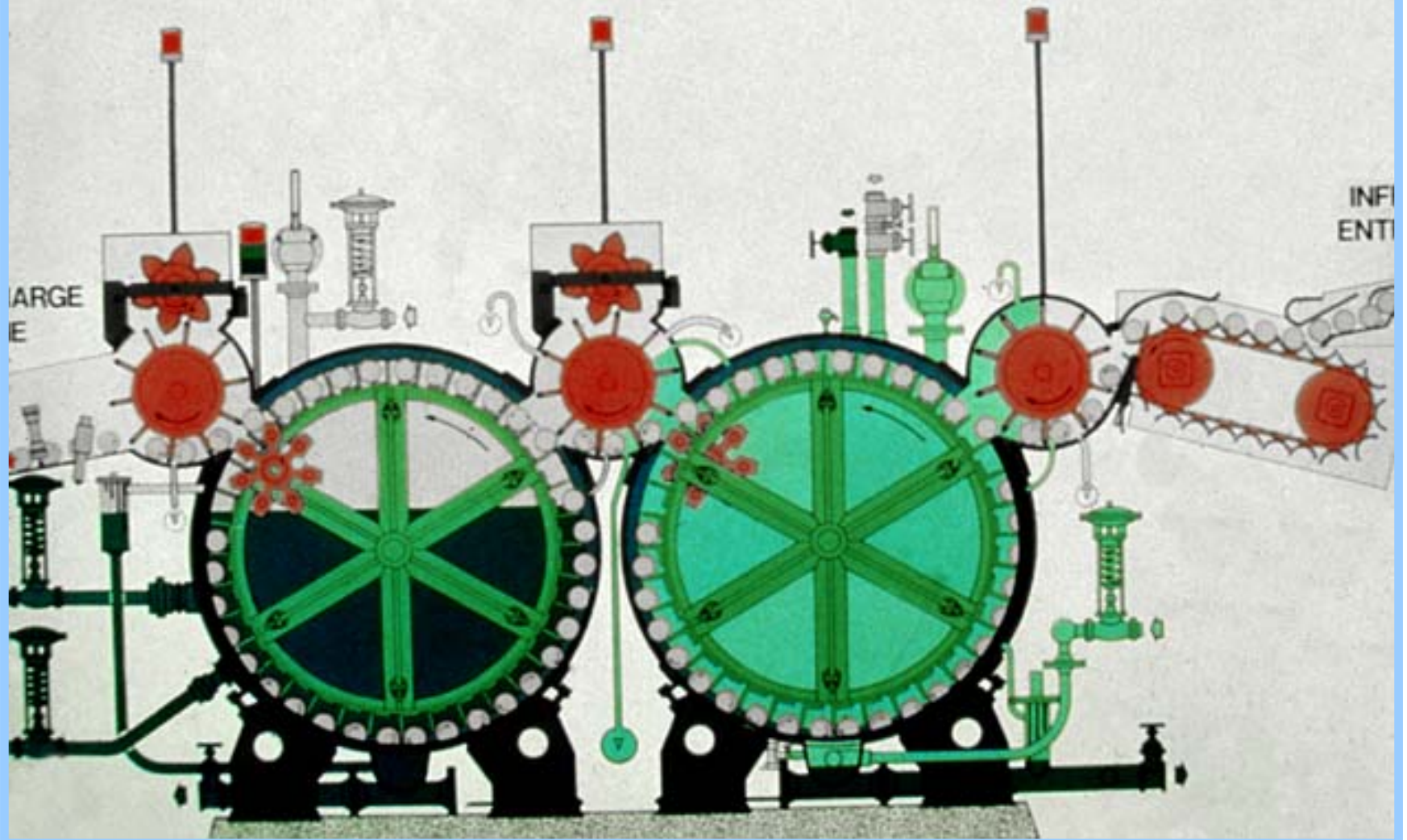



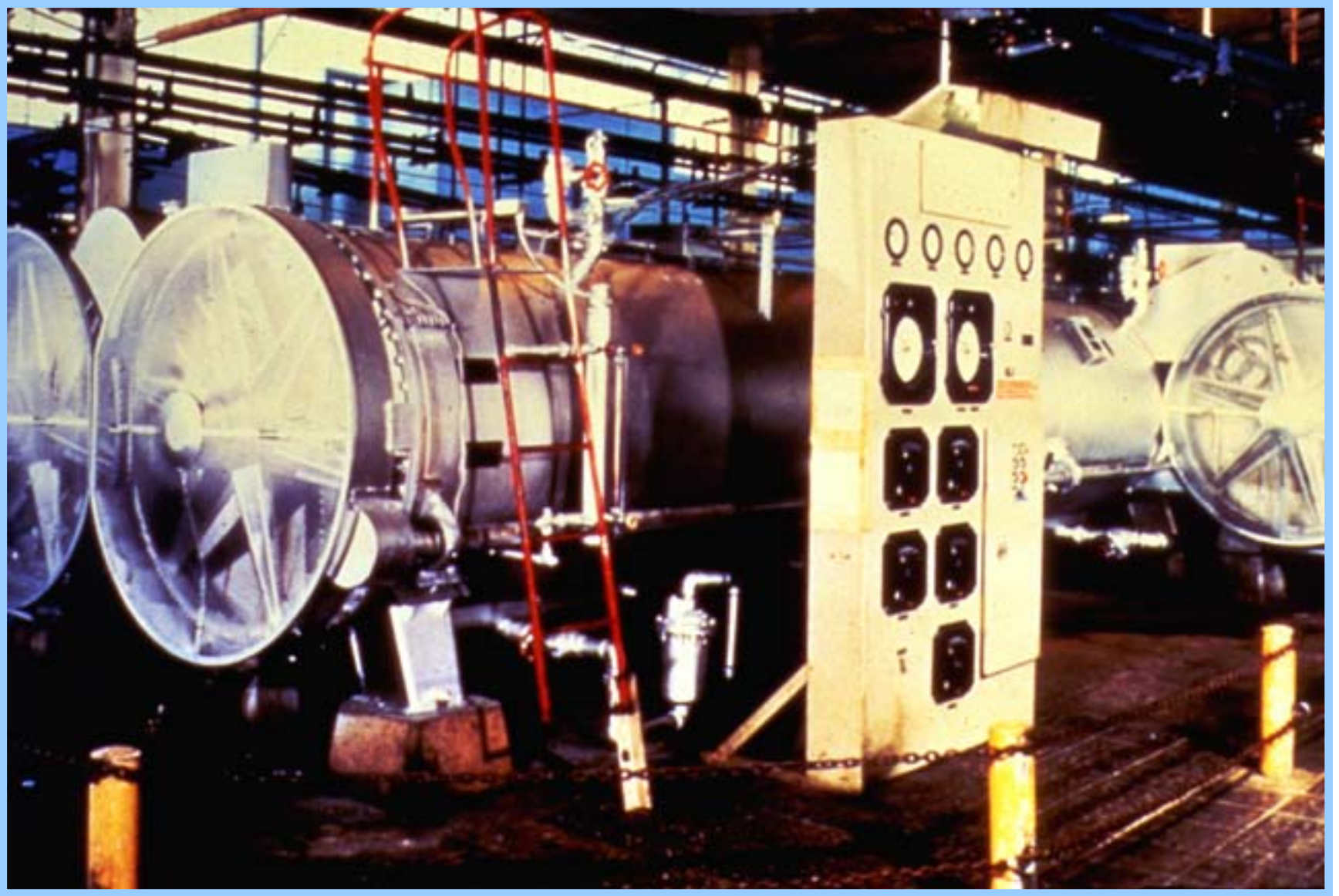

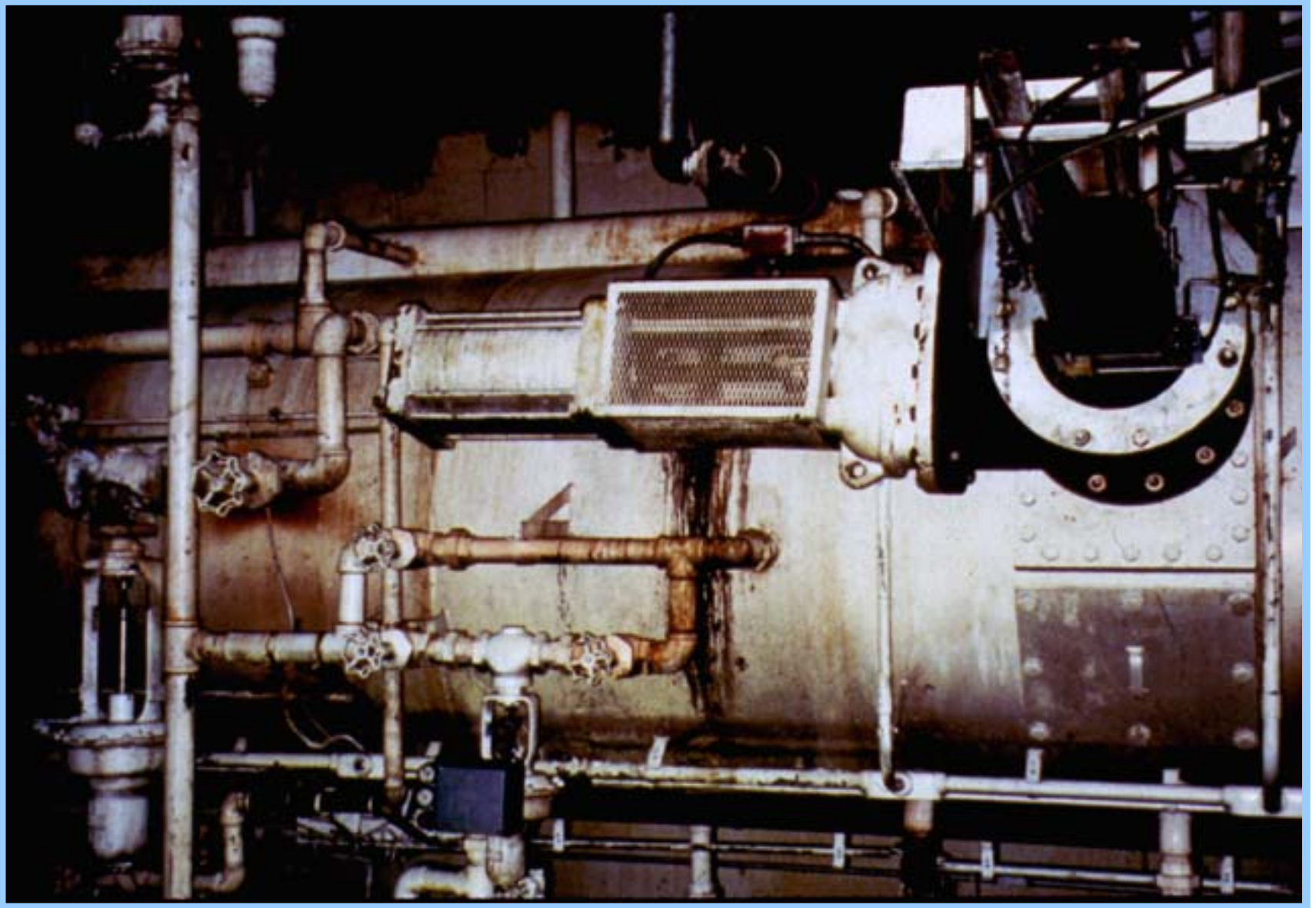

Description of the Retort (continued)

- Containers enter and exit through self-sealing valves p93
- Transfer valve used between pressurized shells



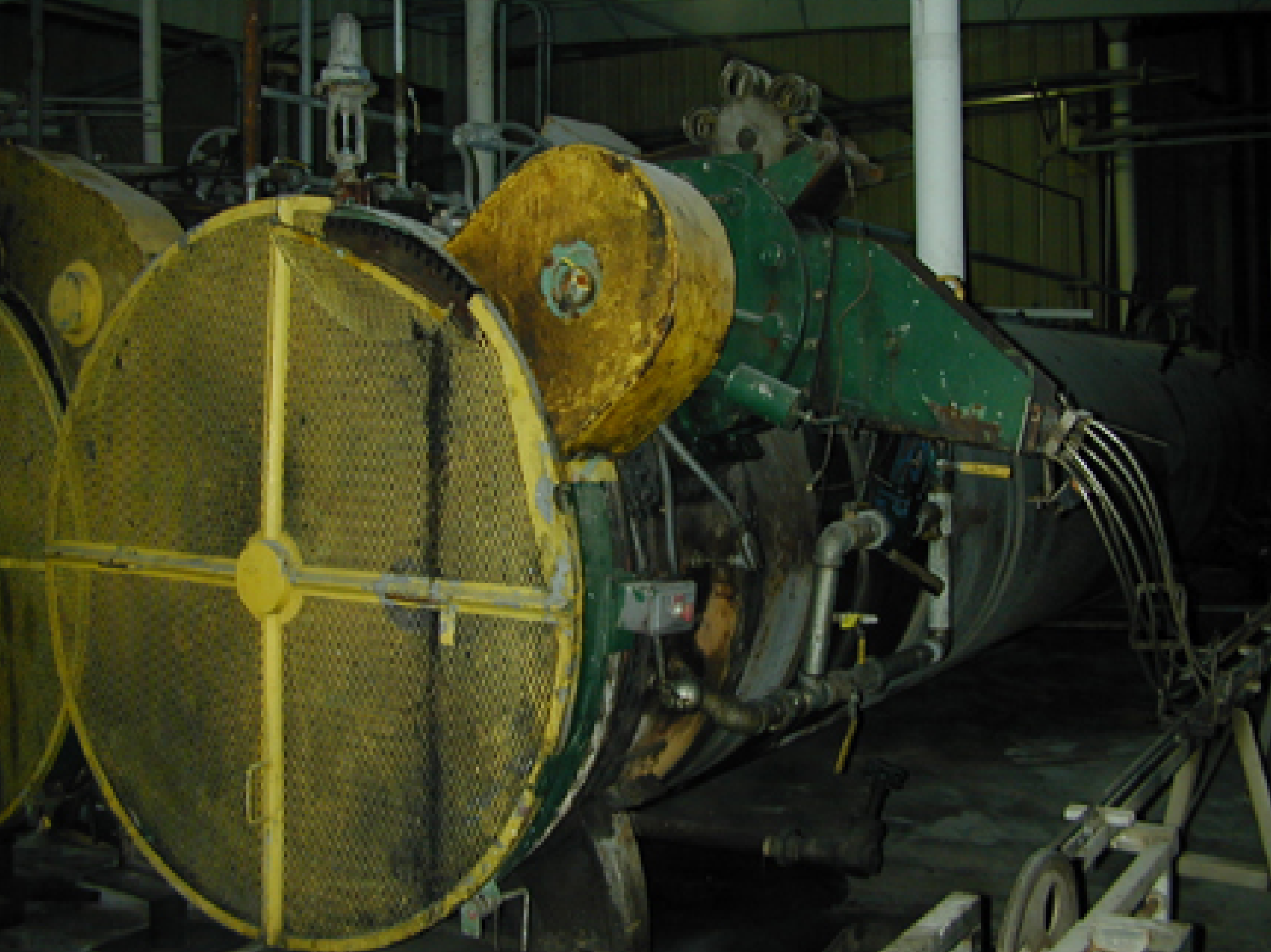

STERILMATIC AGITATION

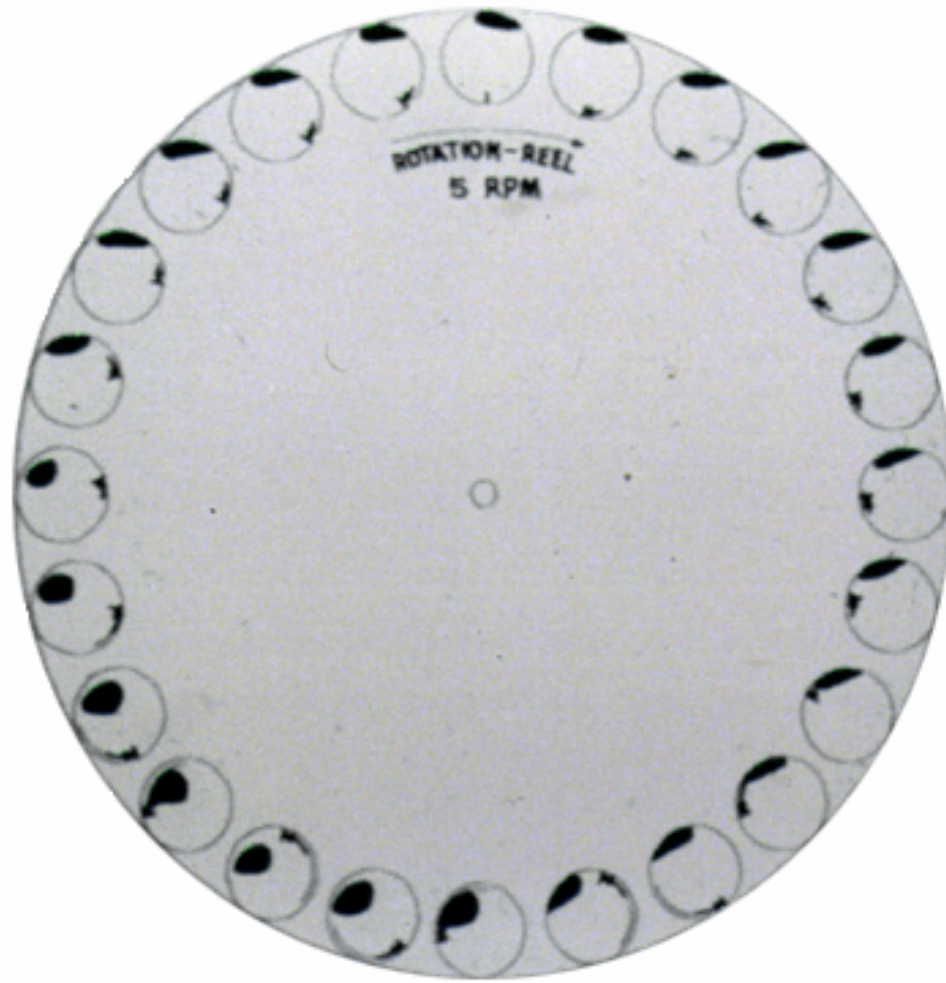

Hydrostatic retorts



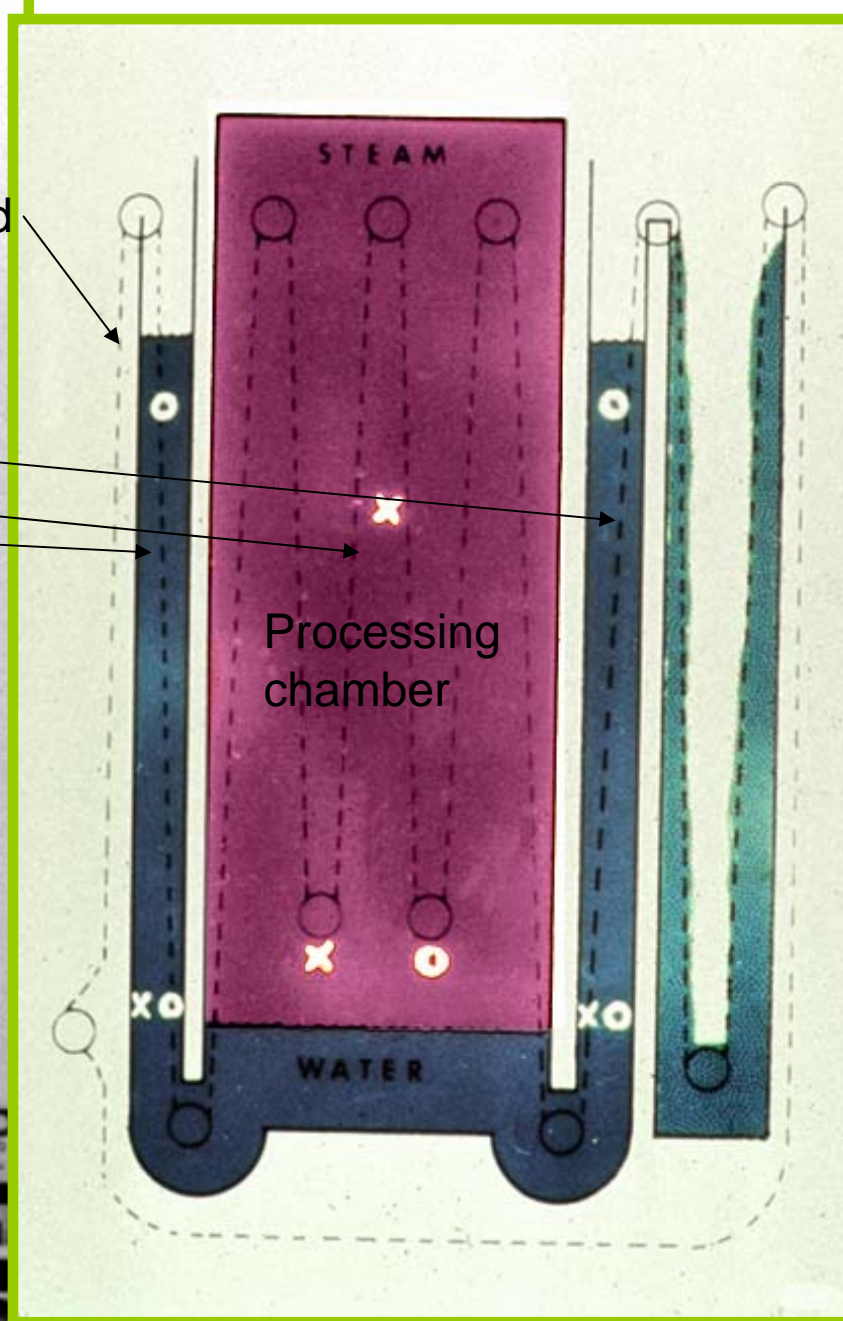
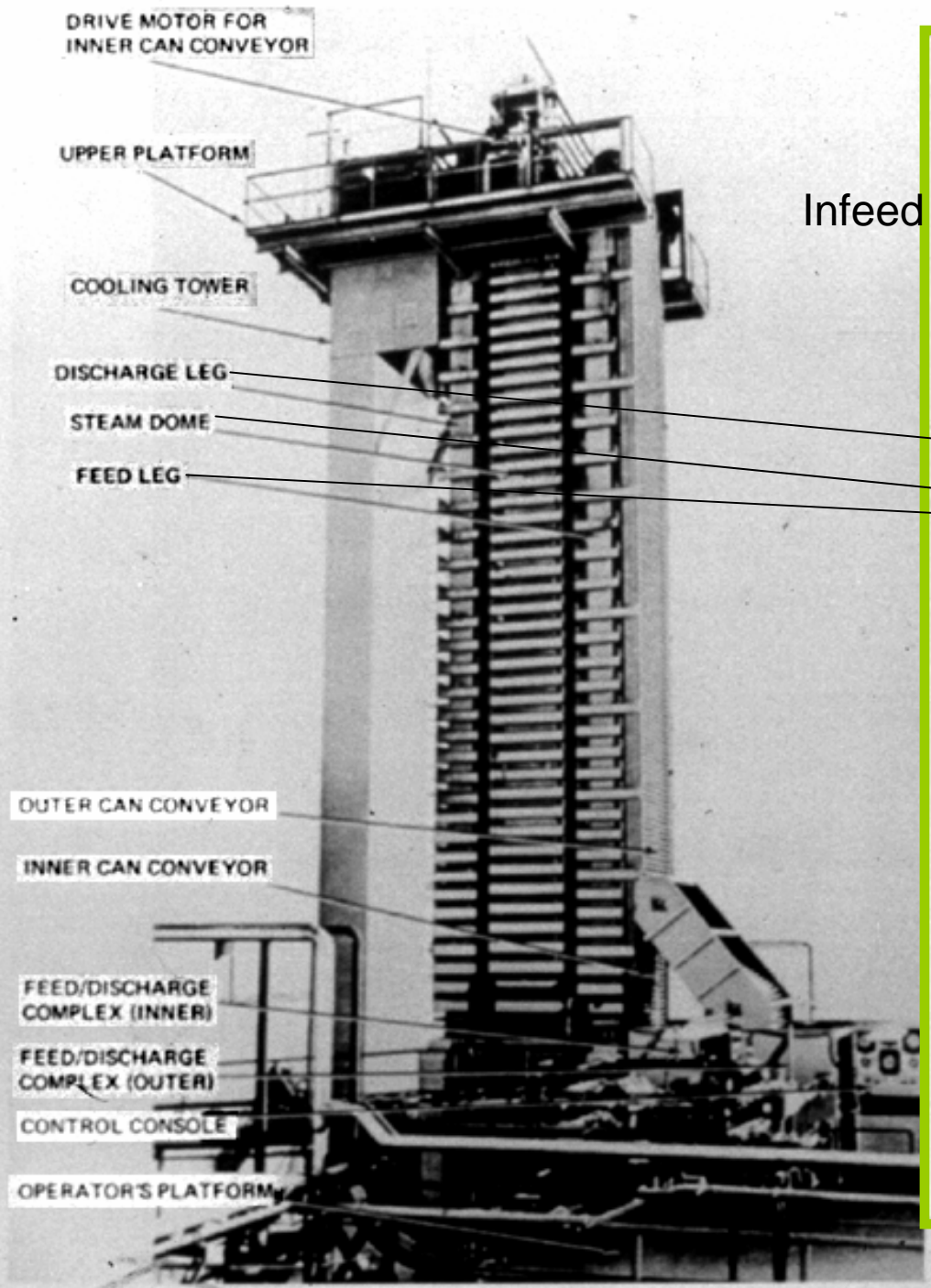

BASIC SCHEME HYDROMATIC STERILIZATION PLANT

PREHEATING

STERILIZING

COOLING

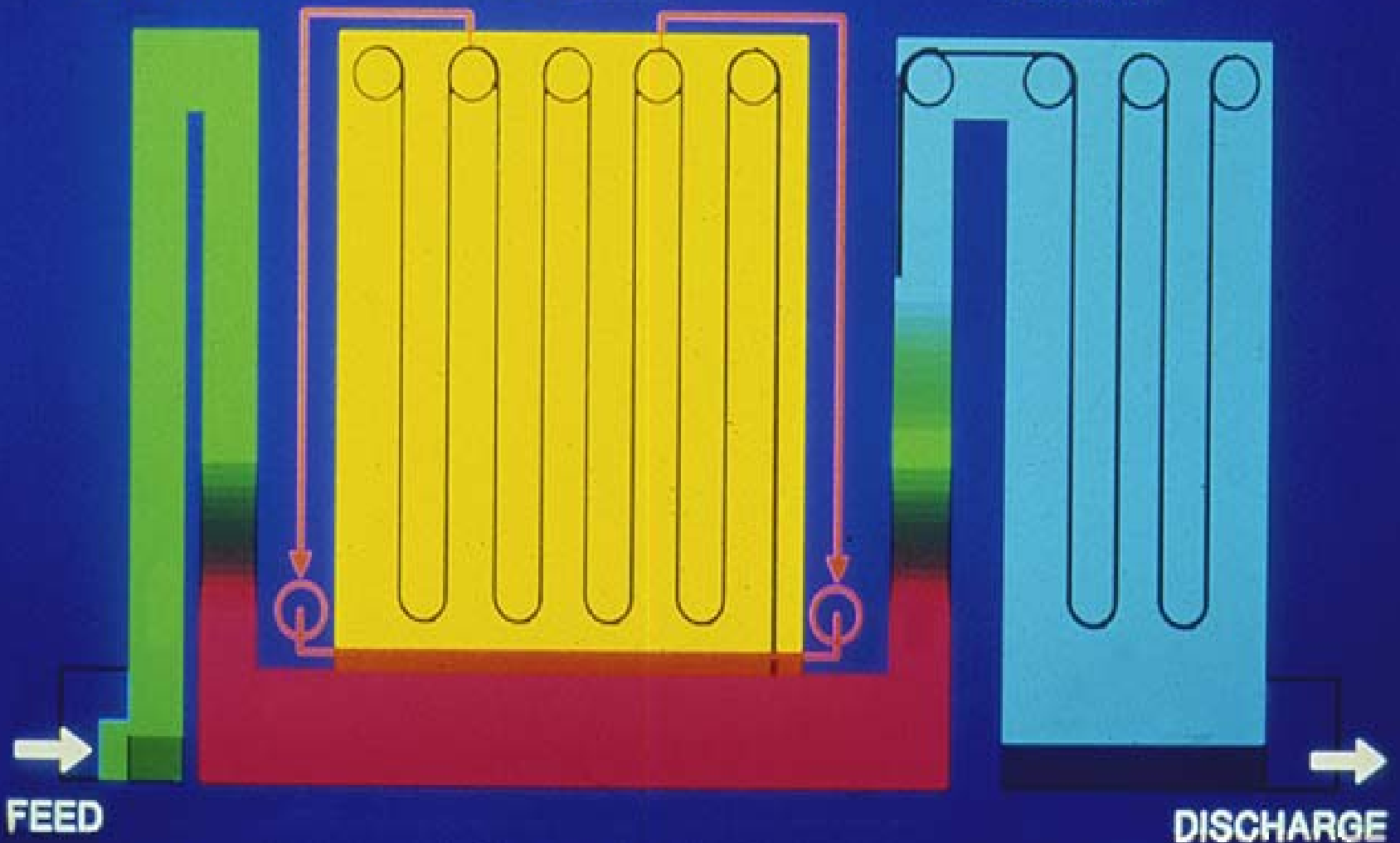

Hydrostatic retorts

- A hydrostatic retort is a continuous agitating retort. Cans are conveyed through the retort by carriers connected to heavy duty chains. The water legs act as valves into the steam chamber and these water legs also balance the pressure in the steam chamber. Cans enter the first water leg where initial warming occurs. The lower the can goes, the warmer the water becomes. The can then travels to the steam chamber where it may make 2, 4, or 6 passes depending on the required process time. The can then passes through the cooling leg where the water becomes cooler as the can rises to a final spray cooler and then a water bath. The can is then off loaded near the entry point.
- Heating and cooling are quite gradual so there are a few strains on the can seams. Cans are rotated axially to speed heat transfer. This system requires reduced floor space and can save energy since it uses regeneration to warm and cool the cans. The water usage is lower than that of conventional retorts. Unfortunately, hydrostatic retorts have a high capital cost and require very high production volumes.

FLAME STERILISATION

- Flame sterilisation involves heating cans by passing them over a gas flame. This method is extremely fast. The can will reach 116°C in a few minutes.
- The cans are closed under a very high vacuum then pass into the four stage process.
- Flame sterilisation **operations**:
 - Cans are first preheated in steam.
 - Cans are passed over a gas flame whilst agitated to stir the contents.
 - The can is held for the required holding time.
 - Can is cooled.
 -
- The entire operations of preheat, process to 130°C, hold and cool takes 12 minutes. The process is limited to low viscosity liquids or solids. The internal pressure in the can during processing is very high and this may strain can seams.

Other retort systems



Stock retorts

Can making

- Manufacture of cans from tinplate is a highly technical and precision operation. At the canmakers plant, in conventional **three piece** canmaking, can bodies are manufactured by first cuffing or slitting rectangular body blanks from the tinplate sheet. These body blanks are then formed into cylinders in a machine which subsequently resistance welds the overlapped edges to form body cylinders at speeds of up to 500 units per minute.
- **Corrugations, known as beads** can be rolled into the can walls to give added strength. The next operation flanges the cylinder in order to receive the can ends and finally one end is double seamed onto the body cylinder to give the finished can, which is pressure tested to ensure an airtight can has been produced before dispatch to the food canner.
- **Can ends** are manufactured in high speed presses which stamp out the desired end profile from strips of tinplate. Subsequent operations also bend around or curl the periphery of the end and line it with a rubber gasket material to ensure a hermetic seal when the end is double seamed onto the body.
- **Two piece DRD (Draw - Redraw)**. In this method of production, a cup is pressed or drawn from a disc of tinplate and this cup is subsequently redrawn, trimmed and flanged to form the two piece can, i.e. no individual bottom end and no side (or body) seam.

Quality Assurance

- Canmaking is a high speed precision engineering industry and throughout all manufacturing operations of slitting, bodymaking, flanging and pressing, curling, compounding and double seaming, extensive checking and charting of measurements are undertaken.
- The integrity of the welded body seam is automatically monitored and controlled by the welding machine. Double seam evaluation involves measurement of at least five parameters and is conducted on line and in the Quality Assurance laboratory. The performance of a canmaking line can be evaluated by entering data into a computer terminal which then can produce rapid statistical analyses.
- In the OA laboratory, microscopic examination of seam cross-sections is a very accurate method of analysing the seam integrity. These modern tools available for quality assurance of canmaking operations have the following advantages:
 - more reliable QA data gathering, computing, storage and retrieval
 - quality improvement through the application of closer tolerances
 - greater integrity of can seams through a management approach towards zero defects

Aseptic Processing and Packaging Systems

Aseptically-packaged foods

- Product processed outside of package, then packaged under aseptic (sterile) conditions into a sterile package
- UHT (ultra high temperature) sterilizers
 - heat exchanger
- Product is heated and cooled very quickly







Definitions

Aseptic

- Absence of microorganisms
- Aseptic, sterile, and commercially sterile used interchangeably

Aseptic System

Combination of processing system and packaging system

Aseptic Packaging System

**Produces commercially sterile, filled and
hermetically
sealed containers**

Basic Aseptic System

Requirements:

- Sterilizable equipment
- Sterile product
- Sterile packages
- Sterile environment
- Monitoring and recording equipment
- Proper handling of finished product

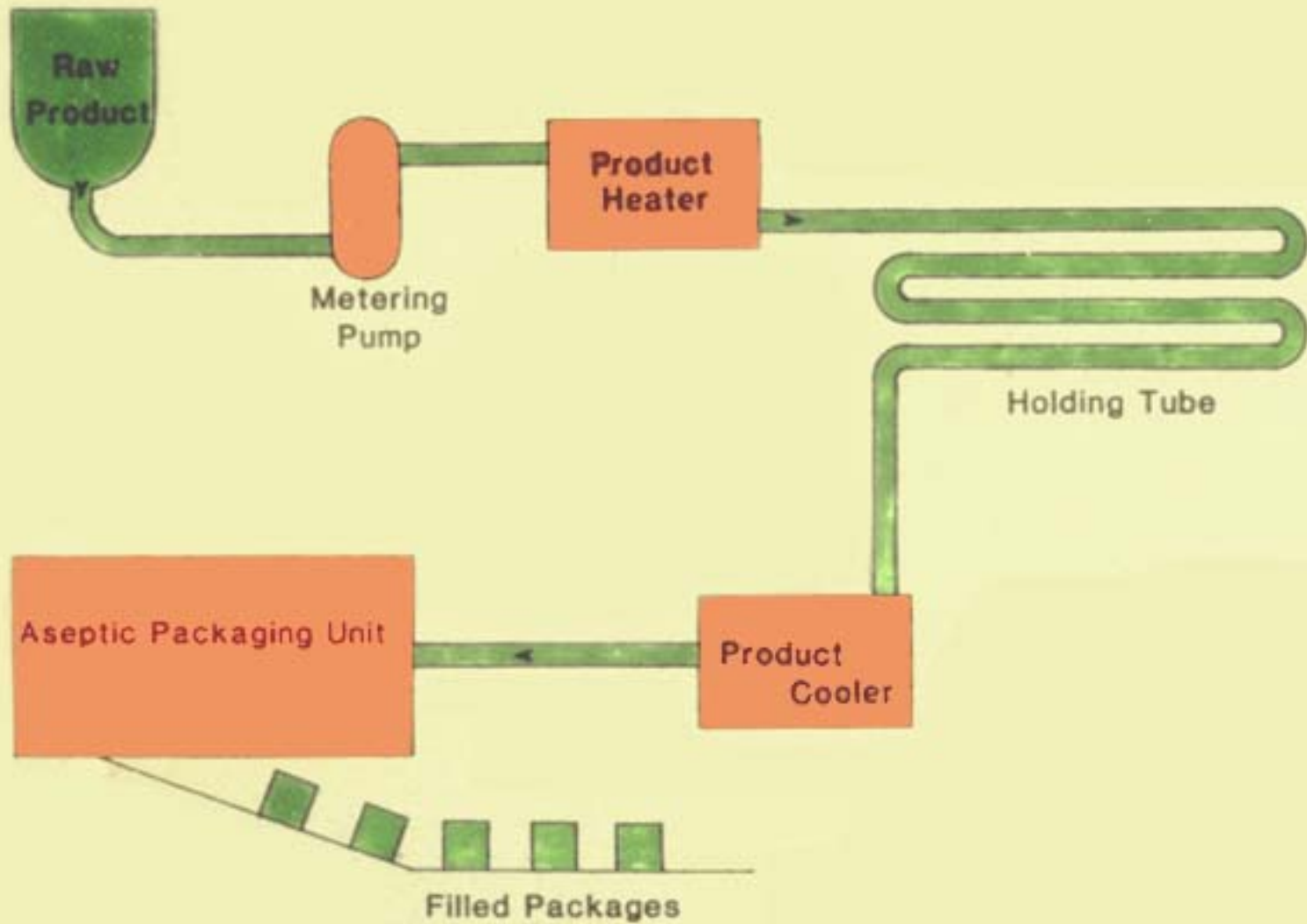

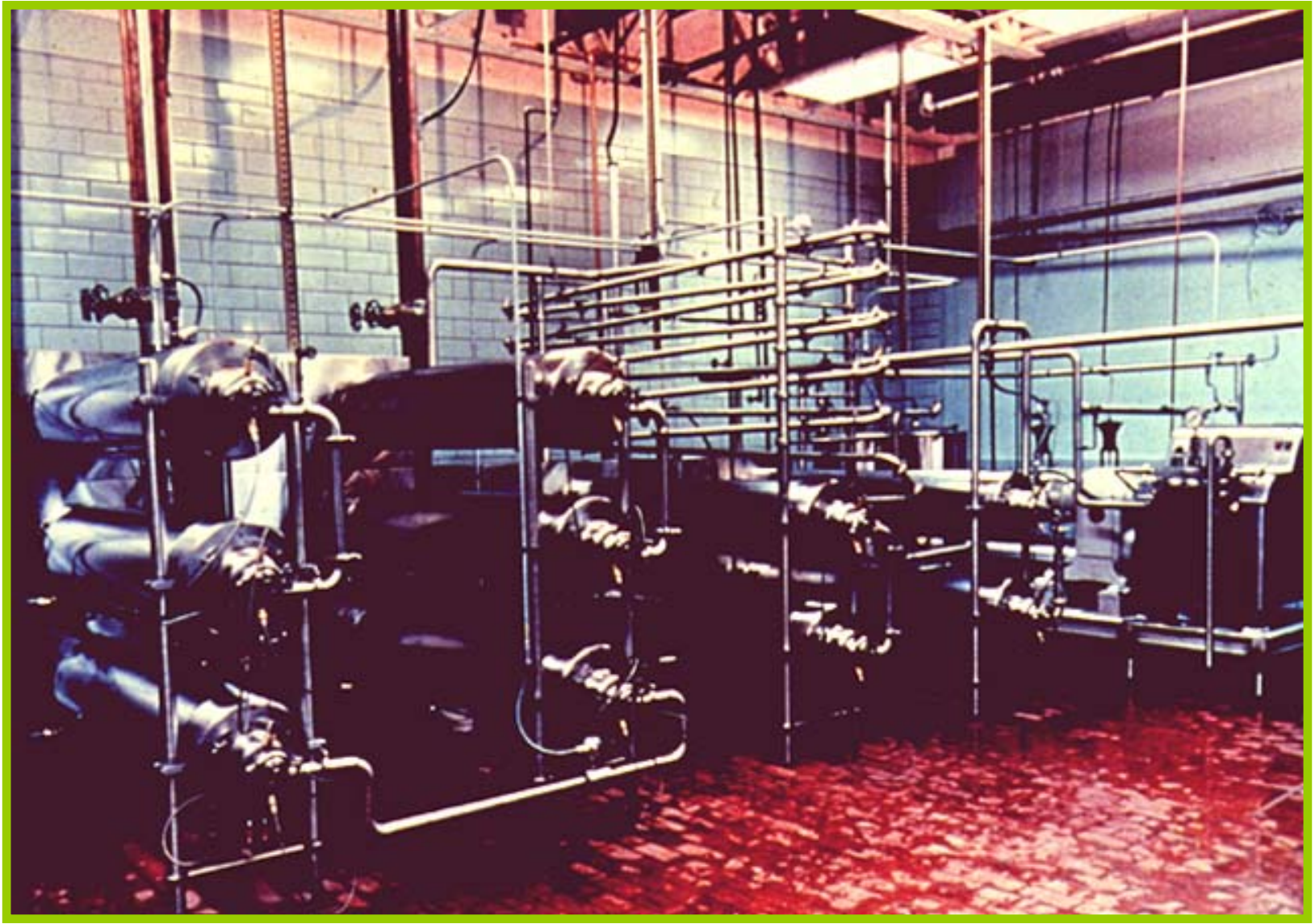

Aseptic Processing System

Common features:

- Pumpable product
- Controllable flow rate (part of scheduled process)
- Method to heat product
- Method to hold product at required temperature and time

Common Features (continued)

- Method for cooling product
- Method to sterilize equipment
- Adequate safeguards

Pre-Production Sterilization

- All product surfaces must be sterile before production and the sterilizing agent must be uniformly effective and controllable
(steam or water)
- Documentation of pre-production sterilization

Flow Control

- Ensure fastest moving particle receives a minimum time at a minimum temperature
- Timing or metering pump controls flow

Timing Pump

- Fixed rate
- Variable speed
- Prevent unauthorized changes

Product Heating

1. Direct

2. Indirect

Direct Heating Methods

1. Steam injection
2. Steam infusion

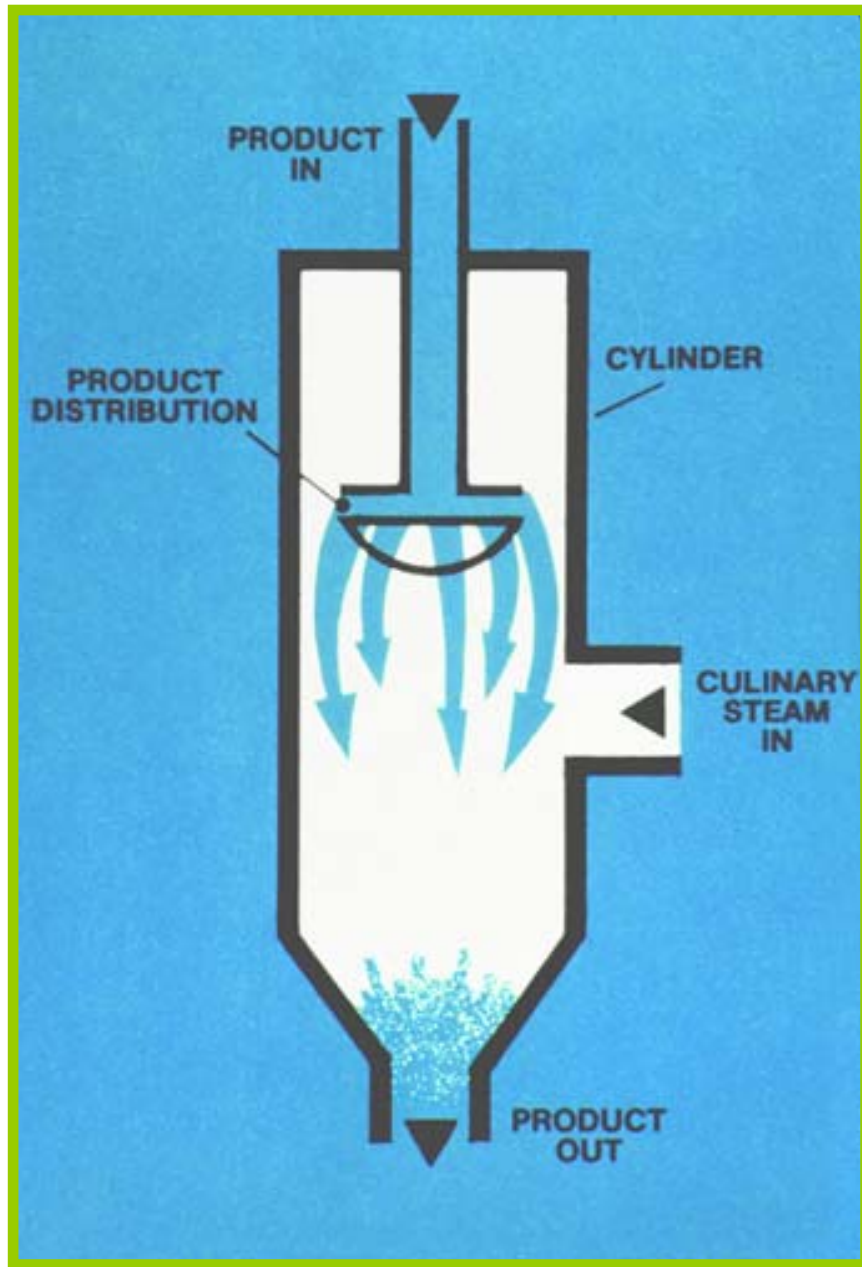

Indirect heating Methods

1. Plate heat exchanger
2. Tubular heat exchanger
3. Scraped surface heat exchanger

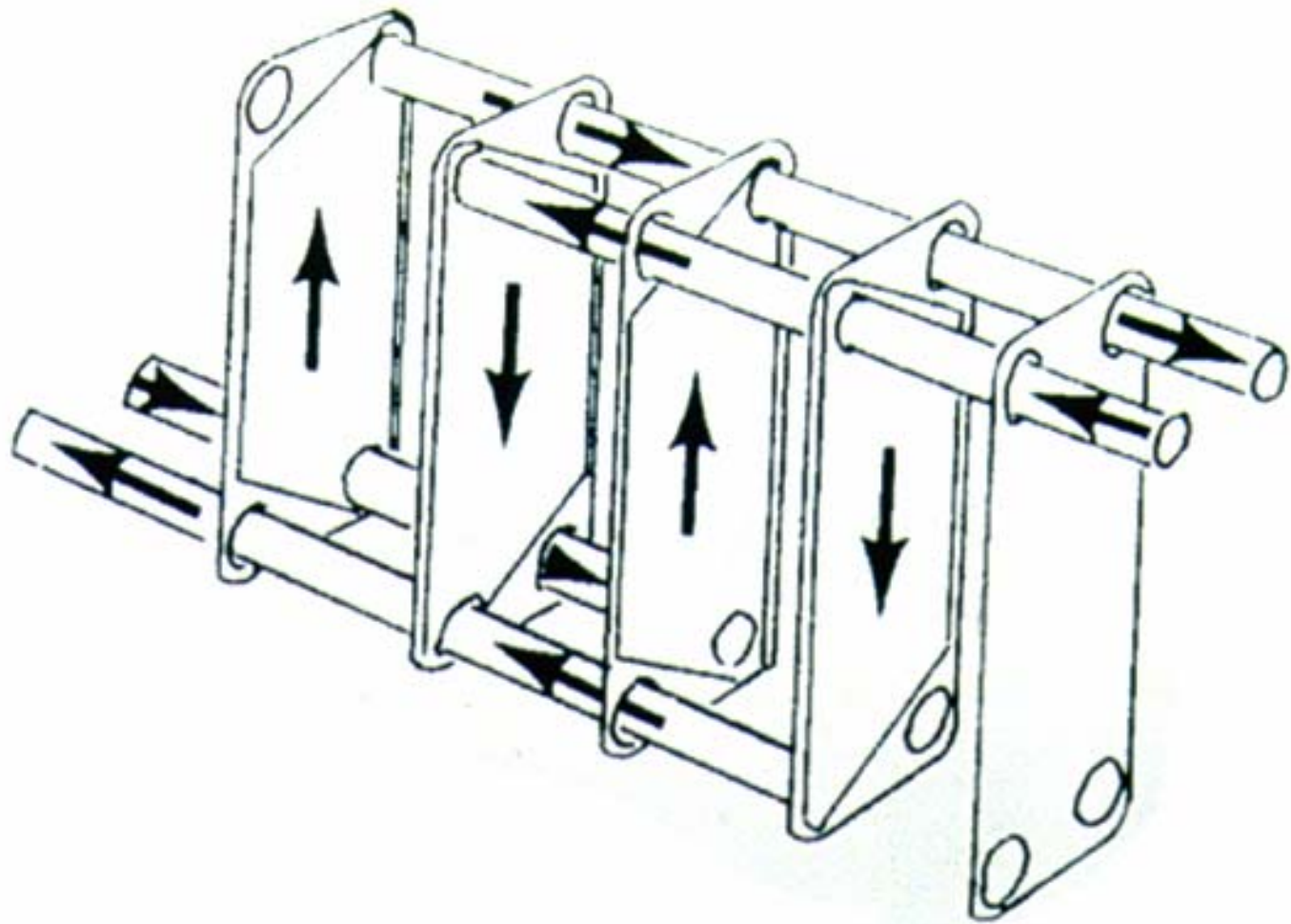

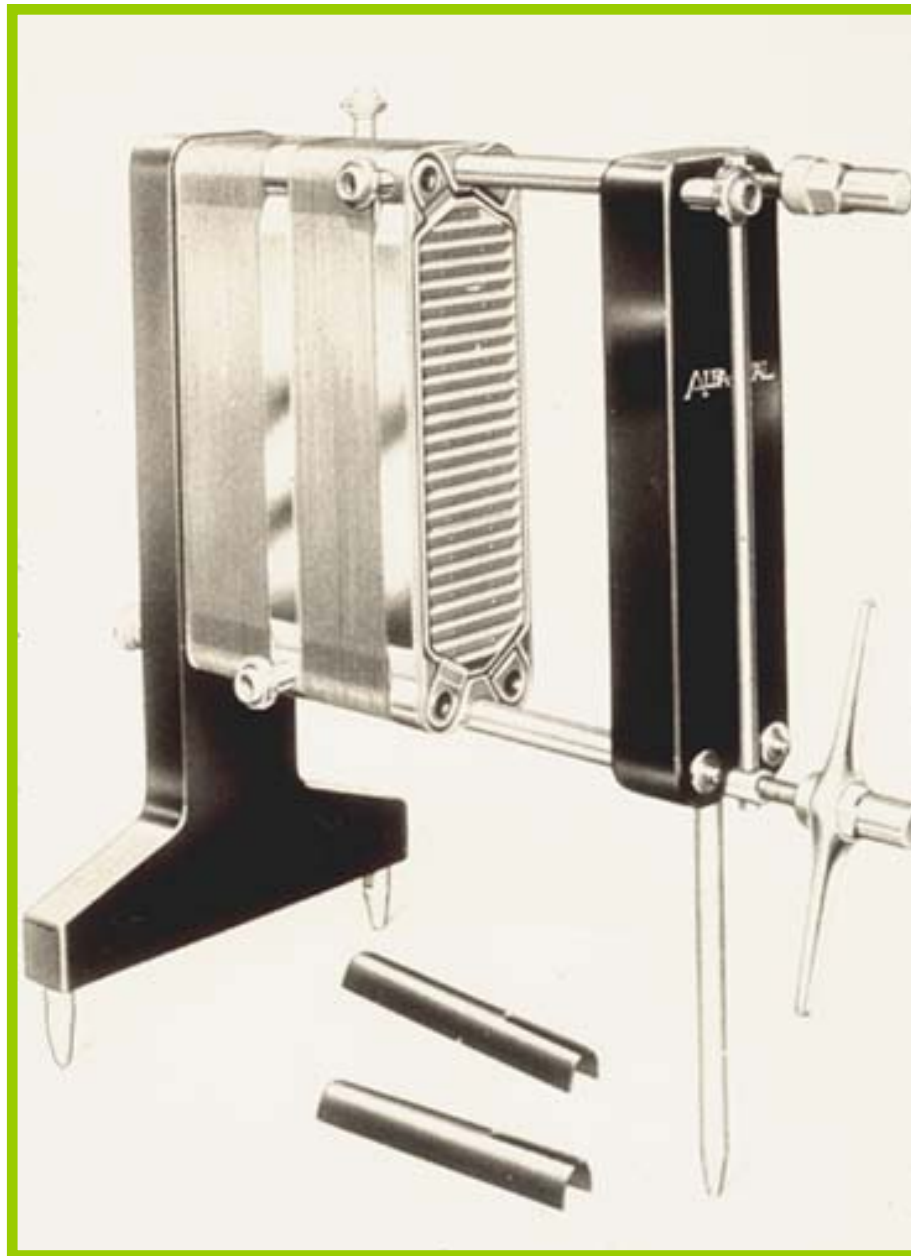

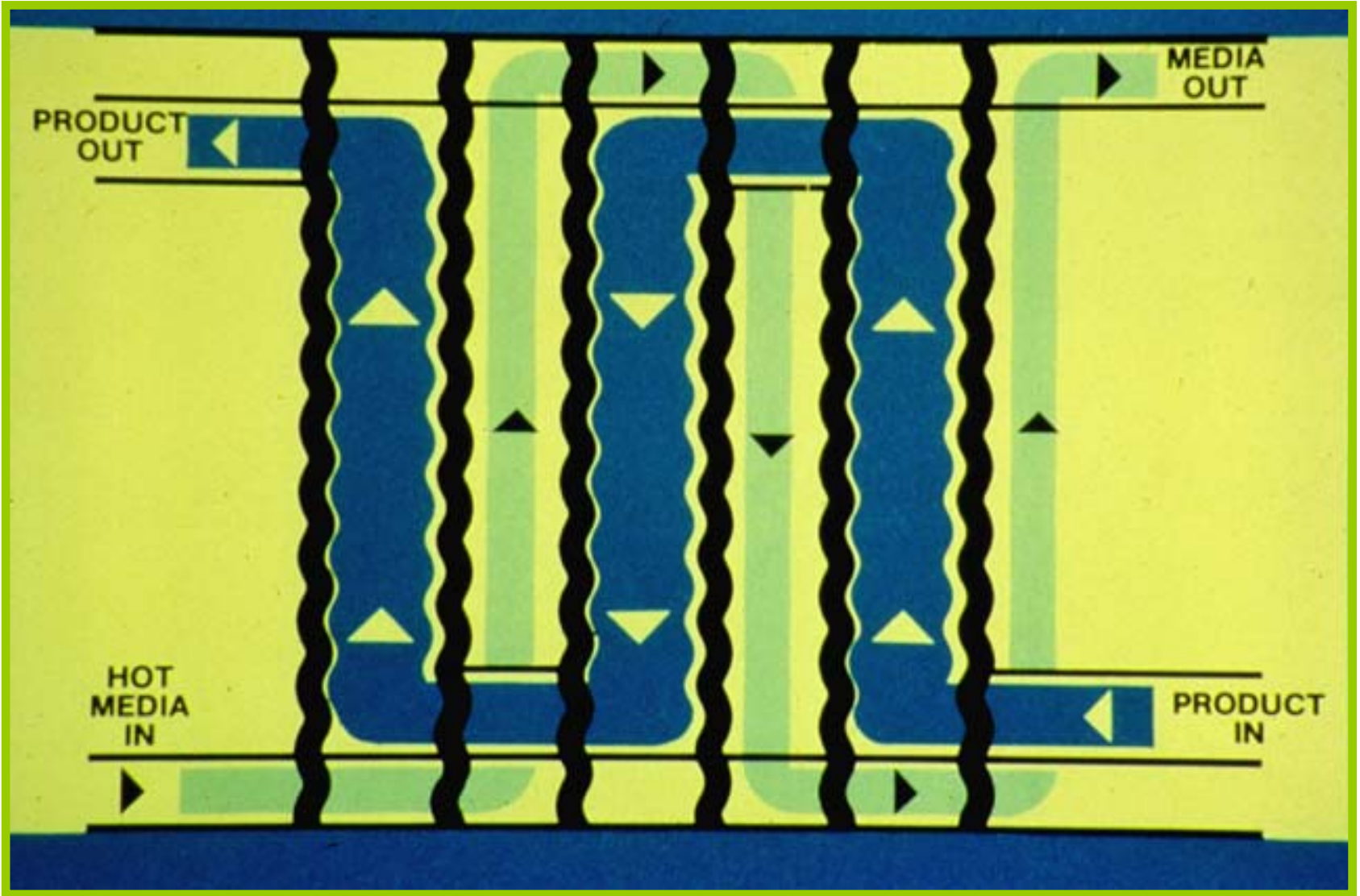

TYPICAL FLOW DIAGRAM OF PLATE HEAT EXCHANGER

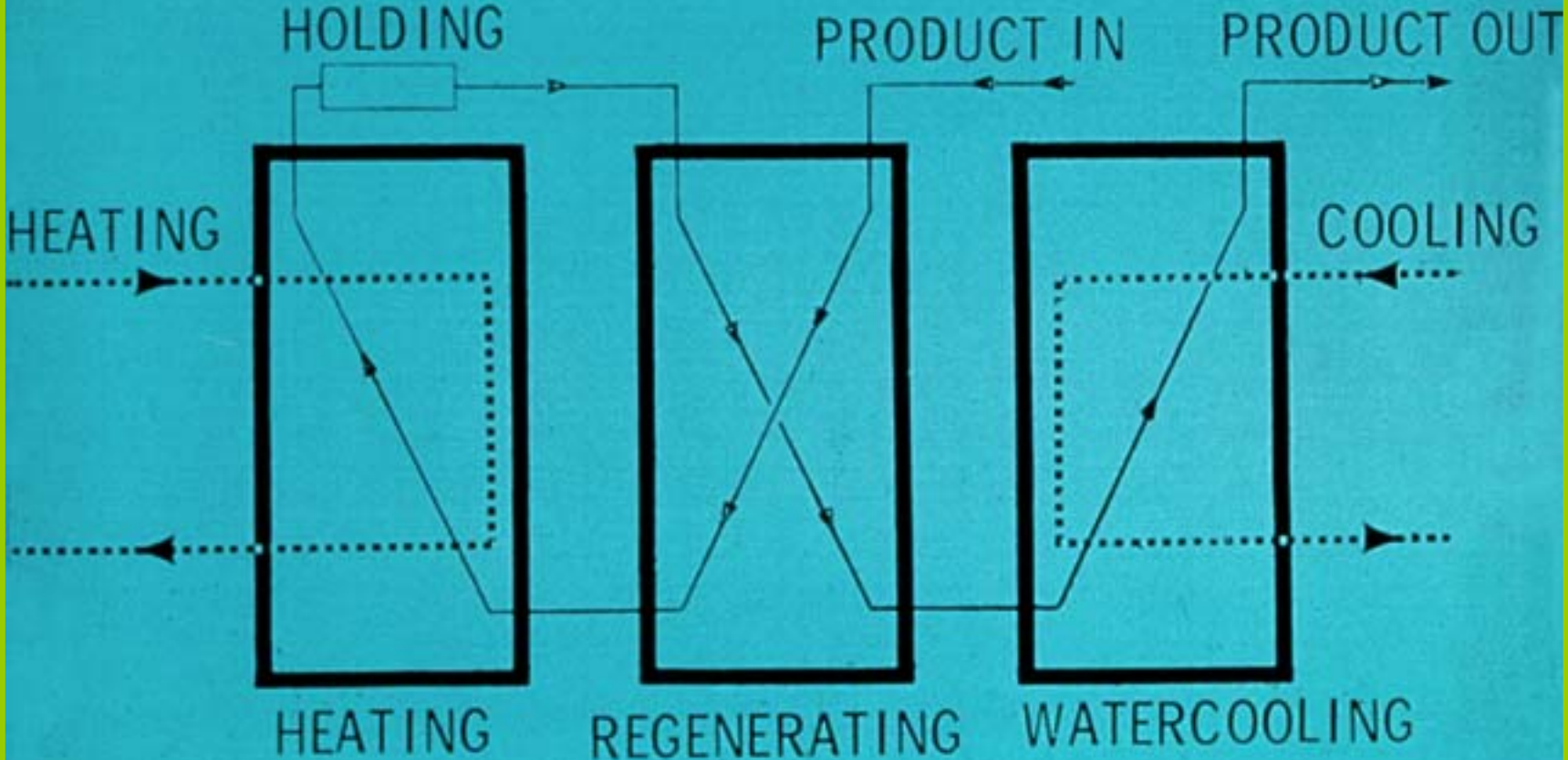

Product-to-Product Regenerator

- Sterile product pressure at least 1 psi above non-sterile product
- Shall have an accurate differential pressure recorder

A

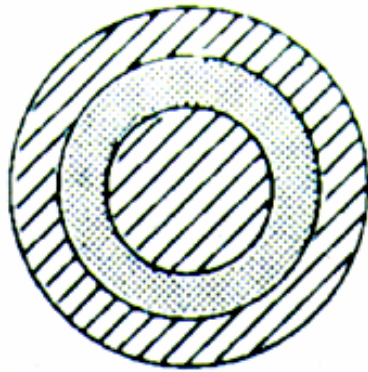

B

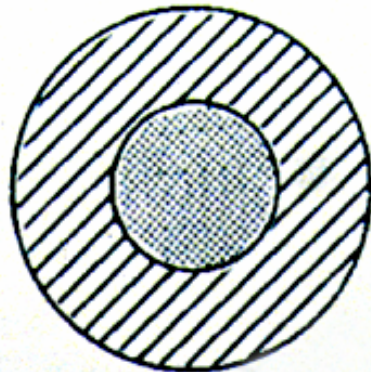

 heating/cooling medium

 product

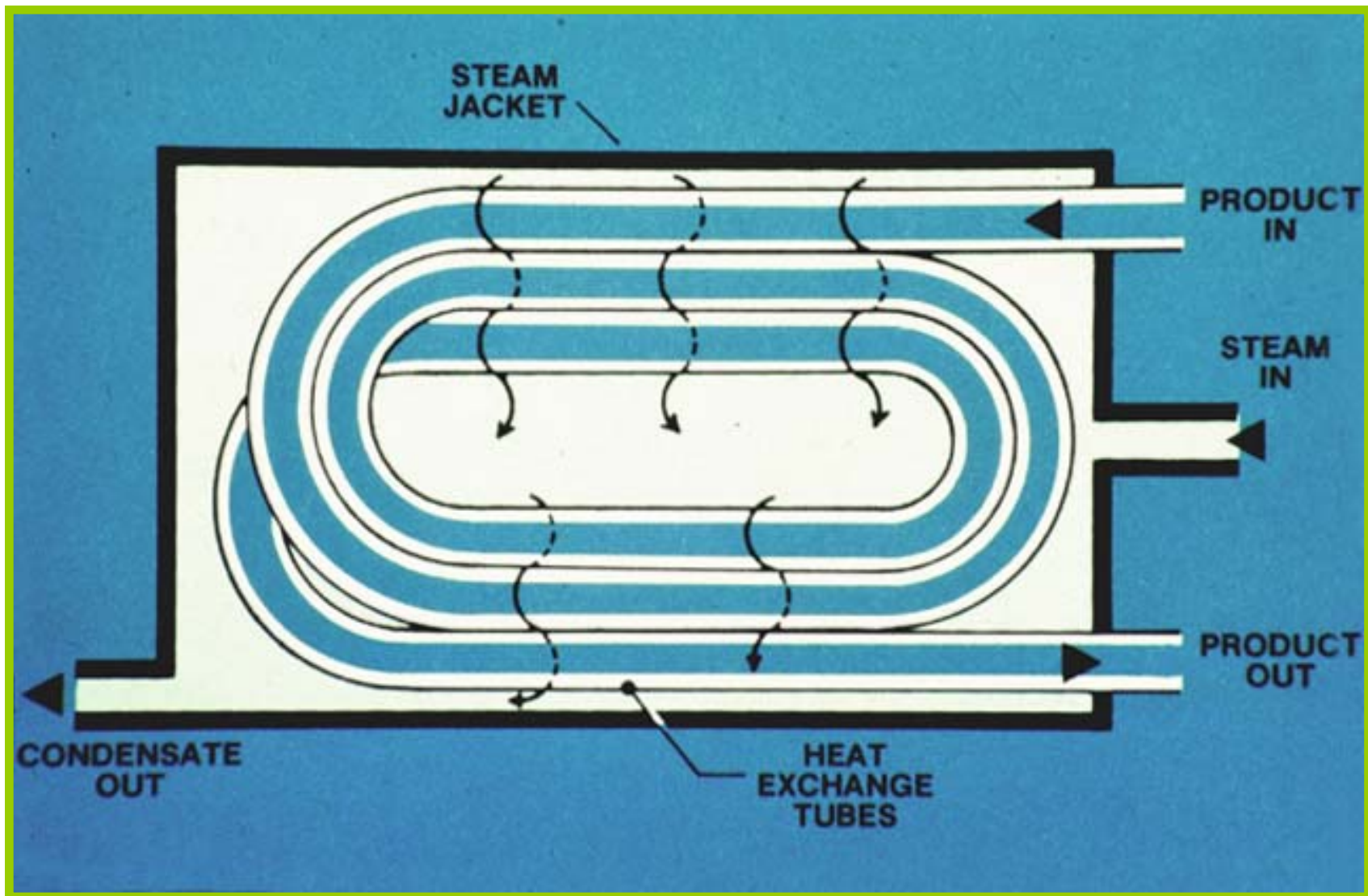

Hold Tube Features

- Sloped upward 1/4" per foot
- Prevent alterations
- Tube interior smooth and easily cleanable
- Free from condensation and drafts
- No heat applied
- Prevent flashing

Monitoring Hold Tube Temperature

- Record and control at inlet
- Record and monitor at outlet

Product Cooling

1. Indirect - heat exchanger
2. Direct - flash or vacuum chamber

Aseptic Packaging- Aseptic Zones

Sterile areas where containers are filled and sealed.

Aseptic Zone

- Entire area
- Sterilants must be uniformly effective and the application controllable
- Sterility must be maintained

Production of Aseptic Packages

Many different types

Incubation

- Holding samples to stimulate growth of microorganisms
- Routine check for sterility
- Incubation mandatory for USDA products
- Not a substitute for good manufacturing practices

Record Requirements

Accurate record keeping is essential

Retort vs. Aseptic packaging

- Both produce a shelf-stable product that retains shelf-life for months to years
- Cost and expertise
- Product quality

Direct and Indirect Continuous Sterilization

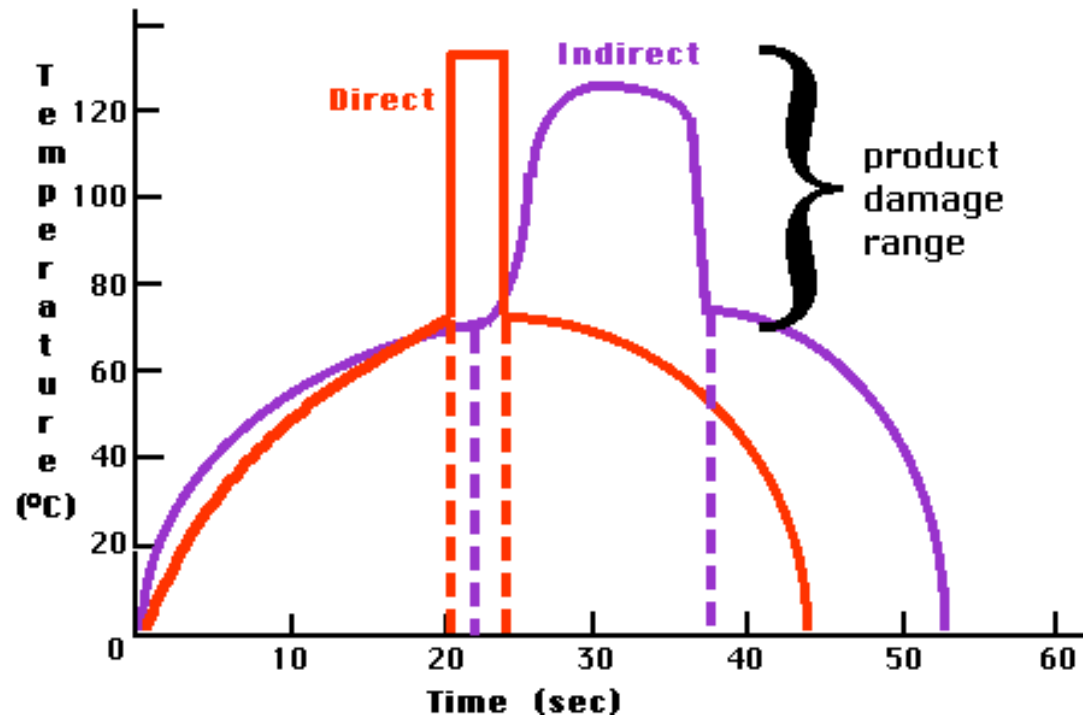

Heat-processed foods

Pasteurized

Commercially sterile – retort and aseptically packaged

Microbial destruction by heat: D-value, F_0

High vs. low acid foods

12-D process for low acid foods

Blanched

Hot-filled

Canned Food Thermal Process Authority Activities

- **Canned Food Thermal Process Authority Activities** Thermal process authority services are the 'specialty' area of IFT programs for food processors. The package of services offered below are essential for food canners utilizing metal cans, glass jar, pouches or other types of containers.
Canned Food Thermal Process Validation Testing: IFT performs heat penetration and temperature distribution testing using the latest computer-aided technology. Digital accuracy combined with years of experience generates accurate validation to insure food safety at your thermal process CCP.
- IFT conducts this testing on virtually all sterilizer/pasteurizer types - still or agitating - utilizing steam, water immersion, steam-air or water spray heating mediums for metal, glass and plastic containers.
- IFT is a '**recognized**' **Process Authority** and a member of the Institute of thermal Processing Specialists (IFTPS).
- **Sterilizer System Audits:** IFT will make an on-site physical assessment of thermal process system using the US FDA Low-Acid Canned Food regulations as reference. From an audit, IFT can confirm regulatory compliance or suggest modifications and/or testing for optimized performance in processing safe thermally processed foods.
- **FDA Process Filing (SID) Assistance:** IFT provides assistance with filing the FD2541 Food Canning Establishment (FCE) registration form and the FD2541a Process filing form (SID). IFT will follow-up with FDA on filing acceptance.
- **Process Deviation Evaluations:** US FDA regulations, and HACCP principles, require that all thermal process deviations be evaluated, and the evaluations and corrective actions be documented. IFT uses its Process Authority expertise to assist packers in meeting these regulatory requirements for thermal process deviation evaluations.
- **Third-Party Validation Data Evaluations:** For those canners developing their own thermal process validation data, IFT offer the third-party evaluation service required by many overseas buyers. We review your data and issue a report on the findings.
- **Validation of Automated Sterilizer Control Systems:** The use of computer aided technology in controlling and monitoring thermal process operations is becoming more common. The design, qualification, operation, maintenance, on-going verification, security and documentation of automated control systems needs to be addressed from a food safety as well as regulatory standpoint.

Better Process Control School

P. M. Davidson, W. C. Morris
and J. Silva

Dept. of Food Science & Technology
The University of Tennessee
and
Mississippi State University

“Canning”

“...a method of food preservation wherein a food and its container are rendered commercially sterile by application of heat, alone or in combination with pH and /or water activity or other chemicals.”

Clostridium botulinum

The prevention of “botulism” illness from the botulinum toxin is the primary purpose of the text and the Better Process Control School

1971 – Bon Vivant Case

- Prompted Industry to ask for regulations in the canning industry (*a rare occurrence*)
- National Cannery Association (**Now the NFPA-National Food Processors Assoc.**)
- **Food Processors Institute** (education branch of NFPA)
- **Major Universities**
- Resulted in CFR 21 Part 113 in 1973 (*Low acid*)
- CFR 21 Part 114 in 1979 (*Acidified foods*)

1921 - 1978 botulism out breaks

233 California

14 Tennessee

Only 18 cases from commercial foods,
and the remainder from home canned foods.

So Why All The Concern?

- The potential is great!
- It is controllable!

The net result was 21CFR 113 titled :
“Thermally Processed Low-Acid Foods
Packaged in Hermetically Sealed Containers”

Effective January 1973 and
modified in 1979

After several “bot” out breaks from domestic and imported acidified foods, Part 114 for acidified foods became effective May 15, 1979.

All these regulations are part of the “Good Manufacturing Practices” regulation.

June 19, 1987

Similar regulations became
effective for USDA - FSIS

The Better Process Control School and the regulations place the responsibility for production of safe food products on individual food industry employees

Canned Foods in Hermetically Sealed Containers

**FDA Regulations and
the Objectives of this
course**

Objectives of Course

- Set forth critical control points in process
- Program organization for effective control
- Emphasize that in certain operations there can be no deviation from prescribed procedures
- Stress proper record keeping

FDA Regulations

Title 21 CFR, Parts:

108 Emergency permit

113 Thermal process/Low acid foods

114 Acidified Foods

USDA (FSIS) Regulations

Title 9 CFR, Parts

318.300 Federal Meat Inspection Act

381.300 Poultry Products Inspection Act

Generally, products containing 3% raw (2% cooked) meat fall under USDA jurisdiction

Emergency Permit Control

Part 108

- Subpart A

Spells out general procedures

- Subpart B

Establishes conditions for thermal processing of acidified (108.25) and low acid(108.35) food packaged in hermetically sealed containers so as to be exempt from or in compliance with the emergency permit provisions.

Highlights of Part 113

- Defines Low Acid Foods
- Products must be in container that can be adequately processed
- Defines a Scheduled Process
- Defines commercial sterility
- States a qualified person design the heating process
- Specifies proper retort systems (design, controls, instrumentation)
- That proper records be maintained (coding, processing, container closure inspections)
- How to deal with retort load that is under processed
- Supervisors and container closure inspectors attend/pass FDA approved school

Highlights of 114

- Defines acidified foods
- Foods excluded from this category
- Procedures for acidification
- Process established by qualified person with knowledge in the area
- Procedures to follow if there's a deviation
- Defines a "scheduled process"
- Describes methods to determine pH/acidity
- Records must be maintained and coding system established for recall
- Supervisors attend and pass approved FDA school

USDA-FSIS Regulations Parts 318.300(meat) and 381.00(poultry)

- Authorized by The Federal Meat Inspection Act and The Poultry Products Inspection Act
- Authorized by two different legislation's, but are essentially the same

“Should vs Shall”

- “Shall” states mandatory requirements
- “Should” states recommended or advisory procedures or to identify recommended equipment

Further reading

- <http://www.foodsci.uoguelph.ca/dairyedu/pasteurization.html>
- <http://www.vhall.nl/International/Chinese/Downloads/HeatPreservation.pdf>
- www-biol.paisley.ac.uk/courses/s_cave/sterilisation.ppt
-